

T.A.C. 1500

Multi-Number Handsfree Telephone Entry System

INSTALLATION and OPERATION INSTRUCTIONS



1220 N. Batavia • Orange, CA 92867
(714) 633-7442 • Facsimile (714) 633-7567

October 25, 2002

TABLE OF CONTENTS

INTRODUCTION	3
PRODUCT OVERVIEW	3
MOUNTING	4
WIRING	4
WIRING DIAGRAM	5
SYSTEM SETUP	
Enter Program Mode Locally	6
Enter program Mode Remotely	6
Initial Set-up	6
Enter Resident Code length	6
Enter Ring Count	6
Enter Gate Interval	6
Enter Call Length	6
Enter Dial Mode	6
Enter Latch Enable / Disable	6
PROGRAMMING	
Programming After Set-up	7
Adding Telephone Numbers	7
Deleting Telephone Numbers	7
Programming Entry Codes	7
Changing the Program Code	7
Deleting Entry Codes	7
Entering Access Cards	8
Deleting Cards	8
Programming Site ID Code	8
Programming Tamper Code	8
Programming (Optional) Time-of-Day Clock	8
Programming Primary Relay "On" time	9
Programming Secondary Relay "On" time (Option).....	9
Master Erase	9
OPERATION	
Calling a Tenant	10
Direct Entry Codes	10
Granting Visitor Entry	10
Denying Visitor Entry	10
Latching/Unlatching Relays	10
Site Identification	10
Remote Operation Time-out	11
Remote Function Tests	11
Printer Operation (OPTIONAL)	11
TROUBLE SHOOTING	12
CONDENSED GUIDE TO USE AND PROGRAMMING	12/13
SPECIFICATIONS / FEATURES	14

INTRODUCTION

This manual contains the information required to install and program the T.A.C. 1500. If you are using this manual to install this unit, it is very important to read all the sections in order.

You should read these instructions before you begin installation. This will insure that everything is done efficiently.

If you are using this manual as a programming guide after the initial installation, you may find the TABLE OF CONTENTS useful in locating the particular programming procedure you need.

PRODUCT OVERVIEW

The T.A.C. 1500 is a multi-number Telephone Entry System for resident/visitor control. Visitors contact the desired tenant by entering a simple directory code. The resident then grants or denies access.

The T.A.C. 1500 has a capacity of up to 400* telephone numbers and up to 400* personal entry codes, and is PBX compatible. It is constructed for rugged outdoor use. Its long-lasting brushed-finish stainless steel housing complements its thin design lines.

***Note:** The maximum number of names that can be displayed on the built-in directory will depend on the font size. The display size is 8.5" x 4". Matching backlit directories are available if extra capacity is needed,

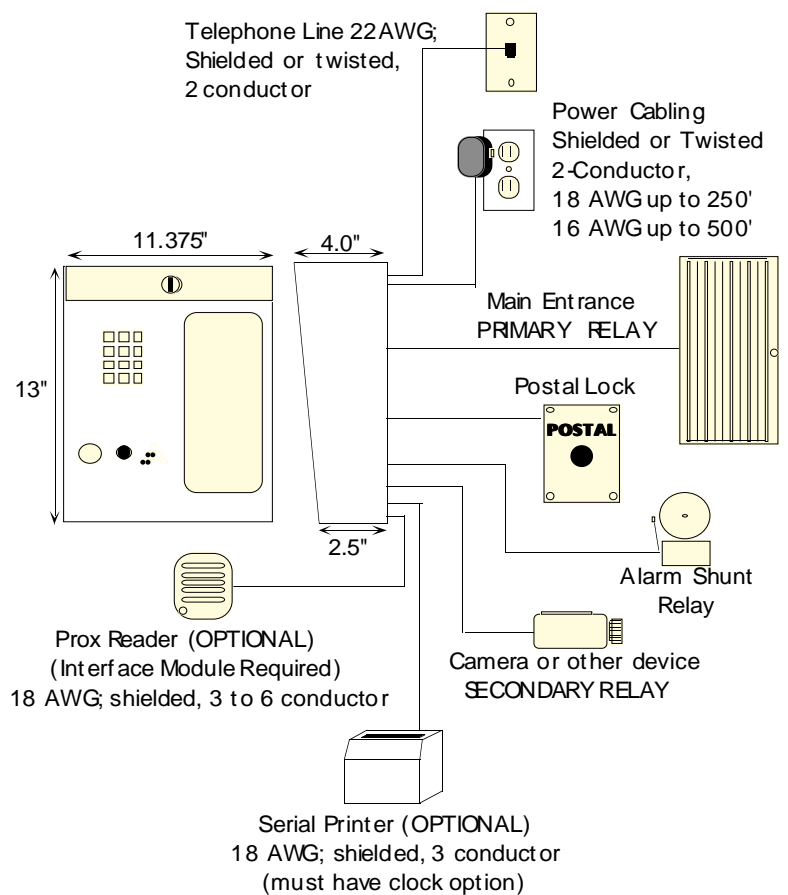
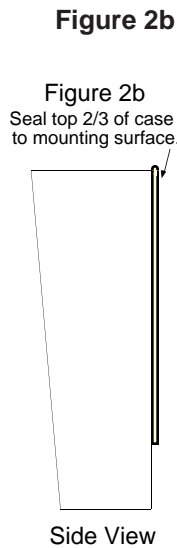

Figure 1

Hookup Specifications

MOUNTING

Figure 2



Arrangements must be made for the installation of a standard voice-grade telephone line (touch-tone or rotary, telco or PBX Port), as close to the unit mounting location as possible. The telephone company may require the following information.

FCC Registration No.....1Z8898-62546-DI-T
 Ringer Equivalence.....0.8B
 Connector.....Terminal Block

When selecting a mounting location,

Trigon recommends some shelter be provided from direct rain and sunlight. An overhang is usually sufficient. If a heater element is installed, be sure to use a bi-metal thermal switch to prevent over-heating during the summer months. Pull the wiring through the access hole in the lower portion of the back plate (Fig. 2). Bolt the plate to the surface through the four .312" mounting holes provided. At this time, the wiring should NOT be energized.

Note: If used in extreme weather, a bead of silicon sealant should be run around the outside top two thirds of the unit, after the front case is secured. (Fig. 2b).

WIRING

1. Use the wiring diagram on pg. 5 for wire connection information.
2. Do not energize wires until installation is completed.
3. Do not power any other device from the Trigon's 12 VAC transformer. If a substitute transformer is used, be sure it is rated 12 VAC, 20VA, UL Class 2 listed. The 12 VAC input power wires should be 18AWG, 600V, insulated wire. This should be sufficient for distances up to 200 feet.
4. Ground the unit by attaching a separate 12 AWG ground wire to the ground location on the terminal block. This ground wire should go to a grounding rod or grounded metal conduit.
5. Trigon recommends that an EMI filter (Cornell-Dubilier Model APF 1021 or equivalent) be mounted between the 12 VAC transformer output and the unit. EMI/RFI filters are available from Trigon. Mount the filter as close to the unit as possible. Ground the filter to the same point as unit ground.
6. Shielded cable is recommended for both the power and telephone cabling. Ground the cable's shield to the same point as the unit and filter. To avoid ground loops, do not ground the shield at both ends. Use 600V insulated wire for this installation.
7. Isolate the phoneline from 12 VAC power wires. This will prevent 60 Hz hum from occurring on the phoneline. Use 22 AWG wire on Telco line run distances of up to 2400 feet. Consult the factory for distances greater than 2400 feet.
8. Primary Relay is a dry contact, Form C type, rated for 5 AMPS @ 30 VDC/ 250VAC.
9. The Shunt relay is a low-power (4 watt) reed relay. It can be used for temporary alarm switch bypass, video camera activation, etc. The Shunt relay activates with the output relay, and deactivates thirty seconds after relay release.
10. (OPTIONAL) Connect printer wiring to the RS-232 port (Printer IN to RS-232 OUT, Printer BUSY to RS-232 DSR, Printer COM to RS-232 COM).
11. If all wiring and grounding is completed, mount the faceplate onto the backbox.
12. Apply power to the unit.

WIRING DIAGRAM

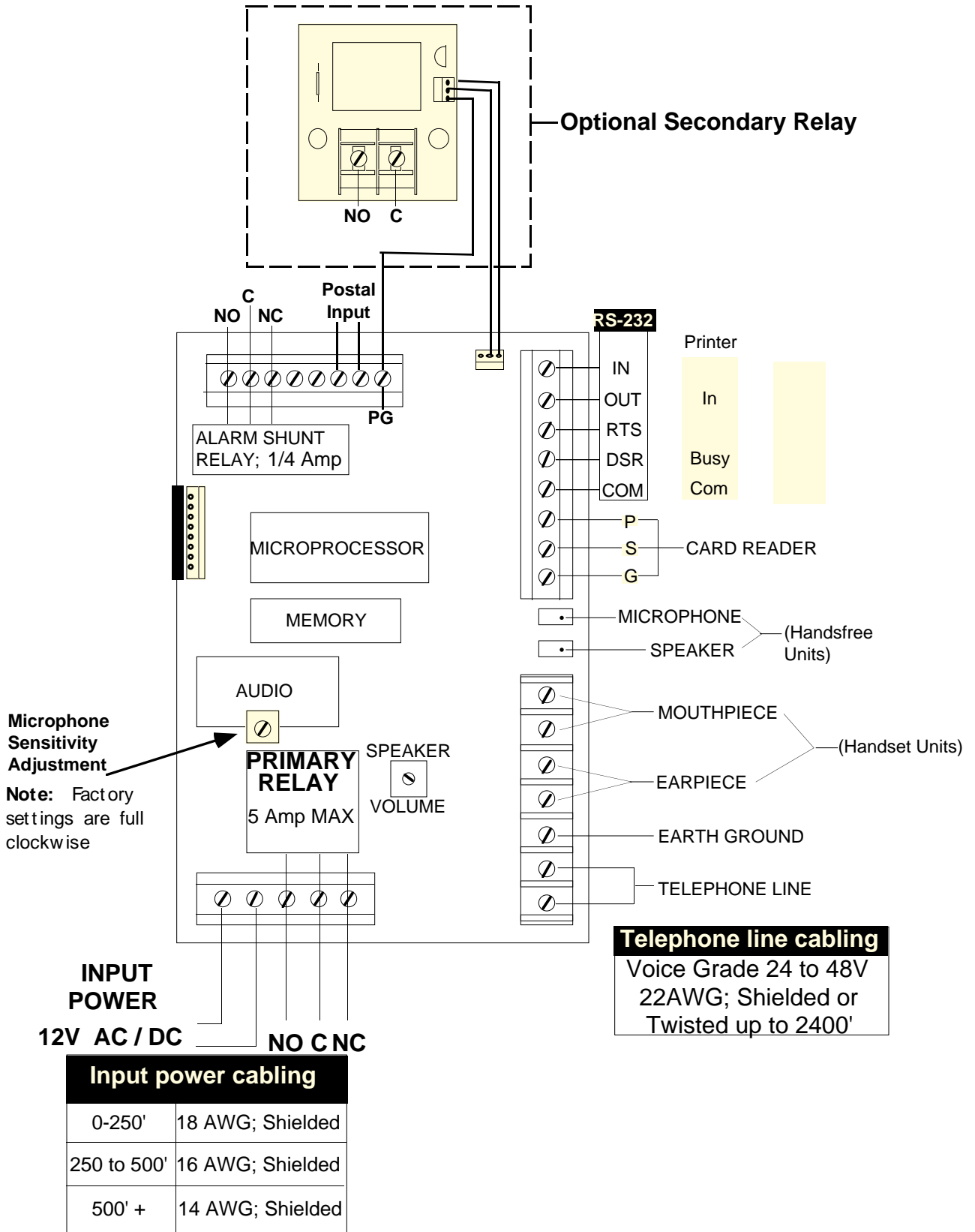

Figure 3

Miniguard II / 100B / Minipak / HF-2

SYSTEM SETUP

General Programming Information:

The "Initial Setup" for the T.A.C. 1500 has been programmed at the factory. These factory default settings may be changed to better suit your particular application. If you decide to alter these settings, follow the instructions below. It is important that each programming step be taken in order. When reprogramming a specific feature, you must always enter the programming mode first. You may then go to the appropriate procedural steps for the changes desired.

Note: It is recommended that you read thru all of the following sections first, before any change is attempted. This will familiarize you with the procedure required. Record any programmed information you wish to change in the spaces () provided. Factory default is displayed in brackets [].

(A) To Enter Program Mode Locally:

1. Press button for dialtone.
2. Enter " * " then enter the unit's Program Code.

If the unit is new, use the preset factory code. (**Factory code is 5269**). You will hear two beeps

-OR-

(B) To Enter Program Mode Remotely:

1. Call the telephone number of the unit.
2. Listen for a single tone.
3. Enter " * " then the unit's Program Code.

If the unit is new, use the preset factory code. (**Factory code is 5269**). You will hear two beeps

(C) To Run Initial Setup:

1. Unit must be in programming mode (see above).
2. Enter "#, 0". This tells the unit that you want to run SETUP. No beeps will be heard.

Enter Resident Code Length:

This will be the number visible on the directory used by a visitor to locate a resident.

Note: Resident codes may be from 1 to 4 digits in length. All resident codes must be of the same length.

3. Enter the resident code length. 1 for one digit, 2 for two digits etc. () [3]

Enter Ring Count:

"Ring Count" refers to the number of incoming rings the T.A.C. 1500 will wait before it auto-answers. This count is adjustable from 1 to 9.

4. Enter the number that indicates the number of rings desired. () [3]

Enter Gate Interval:

"Gate Interval" refers to the length of time the output relay (parking gate, front entry, etc.) will stay engaged after the command has been issued.

For example: Enter "1" for *one 5-second interval*. Enter "2" for *two 5-second intervals (10 seconds)*. Enter "6" for *six 5-second intervals (30 seconds) etc.*

Note: Nine is the maximum..

5. Enter the number of 5-second intervals desired. () [3]

Note: A "0" here will allow the output relay to engage for a one second pulse

Enter Call Length:

"Call Length" refers to the maximum time (in minutes) that the unit will allow a conversation to last.

6. Enter the number (1 thru 4) that corresponds to the call length time (in minutes) that is desired. () [3]

Note: A "0" here allows indefinite call length, however the unit will auto disconnect after 30 seconds of voice silence.

Enter Dial Mode:

"Dial Mode" refers to the type of signal the unit uses to dial a telephone number. The T.A.C. 1500 is capable of dialing rotary/pulse or touch-tone.

Enter "0" if touch-tone is desired.

Enter "1" for rotary.

Enter "2" for Touch-tone dialout and active DTMF keypad after dialout.

Enter "3" for Rotary dialout and active DTMF keypad after dialout.

7. Enter dial mode desired () [0].

Note: Adding TWO to the Dial Mode selection allows the keypad of the T.A.C. 1500 to remain active for use with voice-mail/automated attendant systems, after the initial call is placed and answered.

Enter Latch Enable/Disable:

"Latch Enable/Disable" refers to the ability of the T.A.C. 1500 to latch (hold closed) the #1 relay, from a remote location.

Enter " 1 " to enable the latch feature for relay #1.

Enter " 0 " to disable this feature.

8. Enter latch mode desired () [0].

You will hear two beeps. . . .setup complete.

9. Enter "# #" to exit Program Mode, otherwise, continue programming by entering the desired function code.

PROGRAMMING

(A) Programming after Set-up:

In order to program the unit, it must be in the Program Mode. If you came from SETUP and didn't exit or reset, go on to (B), "Adding Telephone Numbers". Otherwise:

1. Press button for dial tone and enter " * "
2. Enter the Program Code (5269 if unit is new).

You will hear two beeps. The unit is now ready to program.

(B) Adding Telephone Numbers:

1. Unit must be in Program Mode (see section A).
2. Enter Resident Code that you wish to file the telephone number under. (The number will be set from 1 to 4 digits in length.)

You will hear one beep when you have entered the correct number of digits.

3. Enter the telephone number. (The telephone number can be up to 12 digits in length.)
4. Press "# " to complete the entry.

You will hear two beeps. Three beeps indicates memory full.

Repeat the above steps until you are finished.

5. Enter "# #" to exit Program Mode, otherwise, continue programming by entering the desired function code.

(C) Deleting Telephone Numbers:

1. Unit must be in Program Mode (see section A).
2. Enter the Resident Code you wish to delete.

You will hear one beep.

3. Enter "# " .

Two beeps indicate Erasure complete.

Repeat steps 2 and 3 until you are finished.

4. Enter "# #" to exit Program Mode, otherwise, continue programming by entering the desired function code.

Note: If you wish to change a telephone number under an existing Resident Code, use the instructions for Adding Telephone Numbers and enter the new number in place of the old one. The old number will be overwritten.

(D) Programming Entry Codes:

Entry Codes make it possible for the resident to enter a Code (P.I.N. number) at the unit and gain access without placing a call.

1. Unit must be in Program Mode (see section A).
2. Enter "# 1".
3. Enter any 4-digit number between 0000 and 8999.

You will hear two beeps, indicating the number has been recorded in the T.A.C. 1500's memory.

Repeat steps 2 and 3 until you are finished.

Note: Three beeps indicate the code already existed.

4. Enter "# #" to exit Program Mode, otherwise, continue programming by entering the desired function code.

(E) Changing the Program Code:

This feature allows you to change the Program Code to something other than the factory preset of **5269**.

1. Unit must be in Program Mode (see section A).
2. Enter "# 7"
3. Enter 4 digits for new Programming Code.
You will hear two beeps.
4. Enter "# #" to exit Program Mode, otherwise, continue programming by entering the desired function code.

Note: The 5269 Code (or any other previous code) is now invalid, so keep a good, safe record of your new Program Code for future use.

Note: If you lose the ability to access the Program Mode after performing this step, call TRIGON service. We have the ability to remotely reset the Program Code back to default.

(F) Deleting Entry Codes:

1. Unit must be in Program Mode (see section A).
2. Enter "# 2"
3. Enter the Entry Code that you want to delete.

You will hear two beeps. Erasure complete.

Three beeps indicate no Code match found.

4. Enter "# #" to exit Program Mode, otherwise, continue programming by entering the desired function code.

PROGRAMMING, Continued

(G) Entering Access Cards:

This function requires the installation of the **Card Reader Interface option** and a **card reader**. Card access makes it possible for the user to use an access card at the unit and gain entry. Each card entered is converted to a standard 4 digit Entry Code and goes into "Keyless Entry Code memory".

1. Unit must be in Program Mode (see section A).
2. Enter "# 1". (You are in 'Batch Mode).
3. Pass a card through the card reader.

You will hear one beep.

This indicates card number accepted. Three 'beeps' indicates card not accepted.

For next card repeat step 3 until all cards have been entered .

Note: If 3 beeps are heard, that card cannot be used because it already appears in memory. Batch Mode is terminated on this or any fault.

4. Enter "#" when card programming is complete, to return to main Program Mode.
5. Enter "# #" to exit Program Mode, otherwise, continue programming by entering the desired function code.

(H) Deleting Cards:

If the 4 digit value assigned to the card is known, it can be removed from memory with the same procedure as Deleting Entry Codes. Otherwise, from Program Mode:

1. Unit must be in Program Mode (see section A).
2. Enter "#2" and pass the card to be deleted through the reader.

You will hear one beep.

This indicates successful removal.

Note: Three beeps indicates that the card was not in memory, and the Batch Mode is aborted.

3. Enter "#2" to re-enter Batch Mode.

- or -

If the card has been successfully removed

4. Enter "#" to return to normal Program Mode then, continue programming by entering the desired function code.
5. Enter "# #" to exit Program Mode, otherwise, continue programming by entering the desired function code.

(I) Programming Site Identification Code:

In the case of multi-unit installations, the Site Identification Code makes it possible for the party receiving a call from a T.A.C. 1500 to identify which "gate" is calling.

1. Unit must be in Program Mode (see section A).
2. Enter "# 8" and the 4 digit number.

You will hear two beeps.

3. Enter "# #" to exit Program Mode, otherwise, continue programming by entering the desired function code.

(J) Programming Tamper Code:

This feature can be used to alert a manager if the unit is being tampered with. (Four unsuccessful or invalid attempts to enter the programming mode constitutes a tamper.) The unit looks up the Resident Code stored in "tamper" and dials the phone number associated with that resident code.

1. Unit must be in Program Mode (see section A).
2. Enter "# 6" and the Resident Code that you have chosen.

You will hear two beeps.

3. Enter "# #" to exit Program Mode, otherwise, continue programming by entering the desired function code.

(K) Programming Time-of-Day Clock (Optional):

The time of day clock option allows automatic operation of the output relay.

1. Unit must be in Program Mode (see section A).
2. Enter "# 3".
3. Enter the Month. (01=Jan., 02=Feb.,... 12=Dec). Be sure to include the zeros when setting the clock.
4. Enter the Monthly Date. (01 thru 31).
5. Enter the last two digits of the Year.
6. Enter the Hour. Use military time; 00 thru 23 hrs.
7. Enter the Minutes. (00 thru 59).
8. Enter the Day of Week. (1= Mon., 2=Tues, ... 7=Sun.).

You will hear two beeps.

Note: Military time format (24 hour clock) is used in clock programming .

9. Enter "# #" to exit Program Mode, otherwise, continue programming by entering the desired function code.

PROGRAMMING, Continued

(L) Programming Primary Relay on/off schedule:

This feature allows time clock control of Primary Relay. You may set the relay to activate at a certain time of day and deactivate at a later time of the same day. Also, you may set this daily on/off action to happen within a certain part of the week; i.e. Tuesday through Friday.

Note: (TIME Clock Option required) Military time format (24 hour clock) is used in clock programming.

To program Primary Relay, do the following:

1. Unit must be in Program Mode (see section A).
2. Enter "# 4"
3. Enter Start Time (Use military format of hours:minutes, i.e. "0600", "1500"). Entry must be four digits.
4. Enter End Time (same four digit format as above).
5. Enter Start Day and End Day ("1 thru 7" means Monday through Sunday). For example, entering 24 would set the clock for Tuesday through Thursday.

You will hear two beeps.

Note: Day entries must be 2 digits (start and end day).

Note: To program the relay to operate only one day a week, enter the digit for that day twice ("6 6" means Saturday only).

6. Enter "# #" to exit Program Mode, otherwise, continue programming by entering the desired function code.

(M) (Requires Time Clock Option)

Programming Secondary Relay on/off schedule:

This feature allows time clock control of optional Secondary Relay. You may set the relay to activate at a certain time of day and deactivate at a later time of the same day. Also, you may set this daily on/off action to happen within a certain part of the week; i.e. Tuesday through Friday.

Note: Military time format (24 hour clock) is used in clock programming .

To program Secondary Relay, do the following:

1. Unit must be in Program Mode (see section A).
2. Enter "# 5"
3. Enter Start Time (Use military format of hours:minutes, i.e. "0600", "1500"). Entry must be four digits.
4. Enter End Time (same four digit format as above).
5. Enter start day and End Day ("1 thru 7" means Monday through Sunday). For example, entering 24 would set the clock for Tuesday through Thursday.

You will hear two beeps.

Note: Day entries must be 2 digits (start and end day).

Note: To program the relay to operate only one day a week, enter the digit for that day twice ("6 6" means Saturday only).

6. Enter "# #" to exit Program Mode, otherwise, continue programming by entering the desired function code.

(N) Master Erase:

This procedure allows selective or complete deletion of all data in the Minipak's memory. Also, it is possible to reset the T.A.C. 1500 back to its factory defaults (presets).

Note: Use caution when performing these steps.

1. Unit must be in Program Mode(see section A),
2. Enter " #* ".
3. Enter "0" if you wish to erase all data and reset unit back to factory defaults.
4. Enter "1" if you wish to erase all Entry Codes only.
5. Enter "2" if you wish to erase all Resident Code/ telephone numbers only.
6. Enter "3" if you wish to reset the unit back to factory defaults, leaving all other memory intact.

Upon completion of the full master erase sequence, you will hear a long series of beeps.

Note: Master Erase time will vary greatly depending on memory type, usage and capacity.

7. Enter "# #" to exit Program Mode, otherwise, continue programming by entering the desired function code.

OPERATION

Calling a Tenant:

1. Press button for dialtone.
3. Enter the Resident Code.

You will hear tenant answer.

Direct Entry Codes:

1. Press button for dialtone.
2. Enter " # " and your four digit Entry Code (PIN Number).

Granting Visitor Entry:

Answer telephone and identify visitor. You may choose from the following options: (fig.4)

1. Enter "0" to activate Primary Relay and disconnect.

Note: On rotary telephones "5" or higher can be used to activate the Primary Relay.

2. (Option) Enter "8" to activate Secondary Relay and disconnect.

Denying Visitor Entry (disconnect):

To deny entry

1. Enter "7" to force disconnect. Hang up telephone.

Note: It is important that the tenants recognize the responsibility to hang up the Trigon unit by pressing the appropriate key on their telephone's keypad. Otherwise, the visitor may walk away leaving the unit active. Shortly, the loud off-hook indicator tone from the telephone company will be heard for the remaining duration of the call length.

Figure 4

Calls from the gate

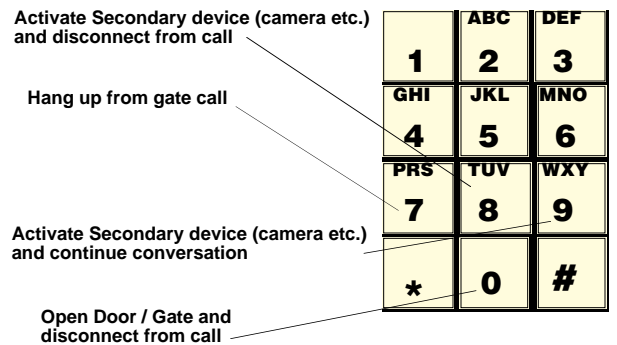

Latching/Unlatching Relays:

This feature must be enabled in the initial SETUP of the unit's programming. Refer to the SETUP section in this manual. To latch (hold closed) a relay, place a telephone call to the T.A.C. 1500. The Minipak will auto-answer and you will hear a brief tone in the speaker. Refer to Fig. 5 for options:

1. Enter "3" to latch primary relay.
2. Enter "4" to unlatch primary relay.
- (OPTIONAL)
3. Enter "5" to latch secondary relay.
4. Enter "6" to unlatch secondary relay.
5. Press "7" to hang unit up.

Figure 5

Latching Keys

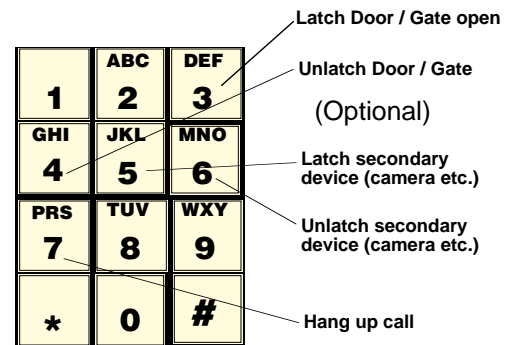

Site Identification:

The Site I.D. number must be programmed into the unit before the feature can be used. See "Programming Site Identification Number"

1. Answer or place call to unit.
2. Enter #.

This instructs the unit to transmit the four digits (tones) of its site I.D. code. The tones may be decoded by using a TRIGON DECODER.

OPERATION (Continued)

Remote Operation Time-out:

If you call the unit to operate it remotely, you have 30 seconds until auto-termination. Any tone instruction will restart this 30 second timer. If you find that you need more than 30 seconds:

1. Enter "8" on your telephone's keypad to extend your call time to three minutes.

Remote Function Tests:

The T.A.C. 1500 has the ability to run a series of self-tests to verify its functionality.

Call the unit. When it answers choose from the following.

1. Enter "0" for touch tone echo test.

Unit will "echo" any touch tone you send with your phone.

2. Press " #" to escape from this test.
3. Enter "1" for memory test. (One tone = good; two tones = bad).
4. Enter "2" for touch tone sequence. (Unit answers by transmitting touch tones 1 through 9, *, and #).

Printer Operation: (Optional)

The T.A.C. 1500 can support an audit log output to a remote serial printer up to 300 feet away.

The printer must be a SERIAL type with a standard RS232 interface connector. The settings of the printer are:

300 Baud, 8 bits, No parity, 1 stop bit.

Serial linkage requires a minimum of three wires that carry "DATA, COMMON, and BUSY".

TROUBLE SHOOTING GUIDE

NO DIAL TONE

1. Check (check fuse) input power at unit. Should be 12 VAC.
2. Check that unit is properly grounded to a good Earth ground.
3. Current starved. Increase AC input wire size.
4. Remove power, wait 5 seconds, restore power. Check for dial tone.
5. Check for phone line. Voltages across terminals should be 48-52 VDC (on hook), 6-12 VDC(off hook).
6. Check VOLUME adjustment on PC board.
7. Check handset connections to PCB.
8. Verify that contacts and wires are clean and tight.

CANNOT PROGRAM

1. Incorrect/lost program code.
2. Not entering "*" before program code.
3. Try 'NO DIAL TONE' troubleshooting procedures.
4. Keypad damaged. Check for vandalism.
5. Check that the Program Prom/Microprocessor is fully seated.

LOSES MEMORY

1. Electrical noise on power line. Install EMI/RFI filter.
2. Excessive electrical noise from strike. Use low current strike.
3. Unit transformer shared with another device (i.e. door strike).

RESIDENT CANNOT ACTIVATE STRIKE/GATE

1. Tenant not pressing correct number on phone.
2. Strike/gate operator not wired correctly.
3. Missing or incorrect power to strike or gate operator.
4. Current starved. Increase wire size.
5. Tone may be too brief in duration (cordless phones, etc.).

AC HUM IN SPEAKER

1. Phone wires running in same conduit as AC power.
2. Unit not properly grounded.
3. Defective microphone.

RESIDENT CANNOT HEAR VISITOR

1. Defective handset/microphone.
2. Too much background or street noise. Relocate unit.

CONDENSED GUIDE TO USE and PROGRAMMING

Legend:

- | | |
|----------|---|
| d | Day of the week (1, 2,...7; Monday= 1) |
| DD | Date (01, 02,...31) |
| eeee | Entry Code (always use four digits) |
| hh | Hour (01, 02,...23) |
| iiii | Site ID Code (always use four digits) |
| mm | Minute (01, 02,...59) |
| MM | Month (01, 02,...12) |
| nnn nnnn | Resident Phone Number (up to 12 digits) |
| pppp | Program Code (4 digits) |
| rrrr | Resident Code (may be 1, 2, 3, or 4 digits) |
| YY | Year (01, 02,...99) |
| * | The "star" key of the telephone |
| # | The "pound sign" key of the telephone |
| ☎ | Tones returned by the unit |

Programming at the Unit:

Enter the Program Mode: Acquire dial tone.

Press " *, Program Access Code".

You will hear two beeps.

Set Unit Parameters:

Press "#, 0", then;

- {3} Set Resident Code Length (1 - 4 digits)
- {3} Set Ring Count (1 - 9, 0= unlimited)
- {3} Set Gate Interval (1 - 9 five second intervals, 0=1 second pulse)
- {3} Set Call Length (1 - 4 minutes, 0= no time-out)
- {0} Set Dial Mode (1= Rotary, 0= Tone) (+{2}= active DTMF keypad after dial out)
- {0} Set Latch Enable Mode (0= disable, 1= enable 1) (☎☎)

USE AND PROGRAMMING GUIDE, Contiued

General:

Data between [] is a mandatory program key stroke sequence. Data between { } is to be supplied by the programmer. Unit responses are shown between ().

Program Phone Number(s):

Press [{rrrr ☎ nnn nnnn #}](☎ ☎)

(☎ ☎ ☎ = memory full)

Add Entry Code:

Press [#1{eeee}](☎ ☎ ☎ = memory full)

Delete Entry Code:

Press [#2{eeee}](☎ ☎ ☎ = already in memory)

Set Clock (Optional):

Press [#3{MMDDYYhhmmd}](☎ ☎ ☎)

Set Primary Relay on/off schedule:

Press [#4{hhmm hhmm d d}](☎ ☎ ☎) –start and stop time, FROM day, and TO day.

Set Secondary Relay on/off schedule (Optional):

Press [#5{hhmm hhmm d d}](☎ ☎ ☎) –start and stop time, FROM day, and TO day.

Set Tamper Code:

Press [#6{rrrr}](☎ ☎ ☎ = error)

Set Program Code:

Press [#7{pppp}](☎ ☎ ☎)

Set Site ID Code:

Press [#8{iiii}](☎ ☎ ☎)

Erase Mode:

Press [#*{t}], (where 0= all data, 1= Entry Codes, 2= Phone Numbers, 3= Defaults, 4=Clean Memory)

Exit Program Mode:

Press [##]

Verify programming:

- [*0] Verify Setup Parameters (sssss ☎)
- [*1] Verify unit capacity (cccc ☎)
- [*2{rrrr}] Verify phone number for Resident Code rrrr (☎ ☎ ☎ = none listed)
- [*3] Verify Clock (MM-DD-YY-hh-mm-d, ☎ ☎ ☎ = none installed)

- [*4] Verify Relay One Schedule (hhmm hhmm d d #, ☎ ☎ ☎ = not set)
- [*5] Verify Secondary relay schedule
- [*6] Verify Tamper Code (rrrr ☎) (☎ ☎ ☎ = not set)
- [*7] Verify Program Code (pppp)
- [*8] Verify Site ID Code (iiii ☎). (☎ ☎ ☎ = not set)
- [*9] List all entry Codes. Press [*] to continue, {##} to stop.
- [**] List all Phone Numbers. Press [*] to continue, {##} to stop.
- [*#] List Audit Data. Press [*] to continue. Press {##} to stop.

Remote Operation:

When the unit is called and auto-answers, press [X] to:

- [0] Echo Tone Test (Press [#] to stop.)
- [1] Memory Test (☎ = good,☎ ☎ = bad)
- [2] Send Tone Sequence (1 - 9, *, #)
- [3] Latch Primary Relay (☎ ☎ = feature enabled).
Latch Primary Relay (☎ ☎ ☎ = error, **not** enabled)
- [4] Unlatch Primary Relay (☎ ☎ = feature enabled).
Unlatch Primary Relay (☎ ☎ ☎ = error, **not** enabled)
- [5] Latch Secondary Relay
- [6] Unlatch Secondary relay
- [7] Force Unit to hang up.
- [8] Extend time-out to 3 minutes (30 sec. Default)
- [9] Toggle Sound (☎ = on,☎ ☎ = off)
- [*{pppp}] Enter Program Mode (☎ ☎ = accepted)
- [#] Send Site ID Code (iiii, ☎ ☎ ☎ = error, not set)

Note: Warning tone occurs 10 seconds before auto hang up.

Specifications / Features

Design- Handsfree telephone with programmable internal auto dial capability and remote control of relays.

Capacity - 24, 50, 125, 300, or 400 residents. Capacity includes 1 to 4 digit directory code, 4 digit direct entry code, and up to 16 digit telephone number for each resident.

System Security- Program Code and tamper code.

Dial Mode - Allows active DTMF keypad after dial out.

Site ID - Programmable 4 digit code.

Call Length - Unrestricted, or limited from 1 to 4 minutes.

Programming - Directly on keypad or remotely by DTMF tones.

Power - 120VAC/12VAC, 40VA, Class 2, transformer included.

Relay Ratings -

Primary Relay: 5 AMPS @ 30 VDC/250VAC;
1/8 HP 120VAC

Alarm Shunt Relay: 250ma @ 12VAC

Relay Activation - Keypad direct entry, postal lock box, push-to-exit button, or tenant.

Relay Output Duration - Programmable; momentary to 45 seconds, or latched.

Telephone Line - Standard touch-tone or rotary. Dedicated or extension line.

Mounting - Surface, with flush or pedestal mount options.

Construction -

- Noncorroding #316 Stainless Steel weather resistant enclosure and backplate with 'tamper resistant' security screws.
- Security microphone assembly.
- Heavy duty fiber speaker.
- Backlit "paper style" directory.



