

Minipak 4000

Multiple Resident Telephone Entry System



INSTALLATION & OPERATION INSTRUCTIONS



255 Glider Circle • Corona, CA 92880
(800) 842-7444 • Info@trigonelectronics.com
www.TrigonElectronics.com

March 1, 2004

TABLE OF CONTENTS

INTRODUCTION -----	3
PRODUCT OVERVIEW -----	3
MOUNTING -----	4
WIRING -----	4
PROGRAMMING	
ENTER PROGRAM MODE -----	6
SETUP SCREEN	
Definitions -----	6
Resident Code Length -----	6
Ring Count -----	6
Gate Time Duration -----	6
Call Length -----	6
Dial Mode -----	6
Active Keypad -----	7
Welcome Screen Duration -----	7
Instruction Screen Duration -----	7
Set Inverse Screen Mode -----	7
Dense Mode -----	7
CLOCK CONTROL SCREEN	
Set Date and Time -----	7
Set Relay, Backlight ON/OFF Timing -----	7
Set Program Code -----	8
Master Erase -----	8
MESSAGE EDIT SCREEN . -----	8
DATABASE EDIT SCREEN -----	8
Resident Code -----	9
Resident Name -----	9
Resident Telephone Number -----	9
Entry Code -----	9
Enroll Access Cards (OPTION) -----	9
Keep File -----	9
Find File -----	9
Delete File -----	9
Next File -----	9
Clear -----	9
Quit -----	9
TENANT FILE EDITING -----	9
DISPLAY EDITING -----	10
OPERATION	
GRANTING A VISITOR ACCESS -----	11
DENYING VISITOR ACCESS -----	11
TROUBLESHOOTING -----	12

INTRODUCTION

USE OF THIS MANUAL

This manual contains all of the information required to successfully install and program the Trigon MP4000. If you are using this manual to install this unit, it is very important for you to read the following sections in order:

You should read these instructions before you begin the installation. This will insure that everything is done efficiently.

If you are using this manual as a programming guide after the initial installation, you will find the TABLE OF CONTENTS helpful in locating the particular programming procedure you desire.

PRODUCT OVERVIEW

The TRIGON MP4000 is in itself a complete Access Control Security System. It makes use of an ordinary telephone line to provide complete remote control of an entrance point and/or its monitoring equipment. It allows visitors to make contact inside the building they wish to enter. Personnel inside the building answer the incoming telephone call and, with a touch of a button on their Touch-tone telephone, they grant or deny the visitor's entrance. Likewise, it allows tenants/employees a means of direct entry via code or card.

Two relay outputs make it possible to control a camera as well as a barrier. Barriers may be latched open under control of an on-board Time-of-day Clock. A third on-board relay, herein referred to as the "Shunt" Relay, is a low-power device that can be used to disable an alarm switch during authorized visitor/tenant entry. Records of entry/exit activity are made possible with a Serial Printer Output.

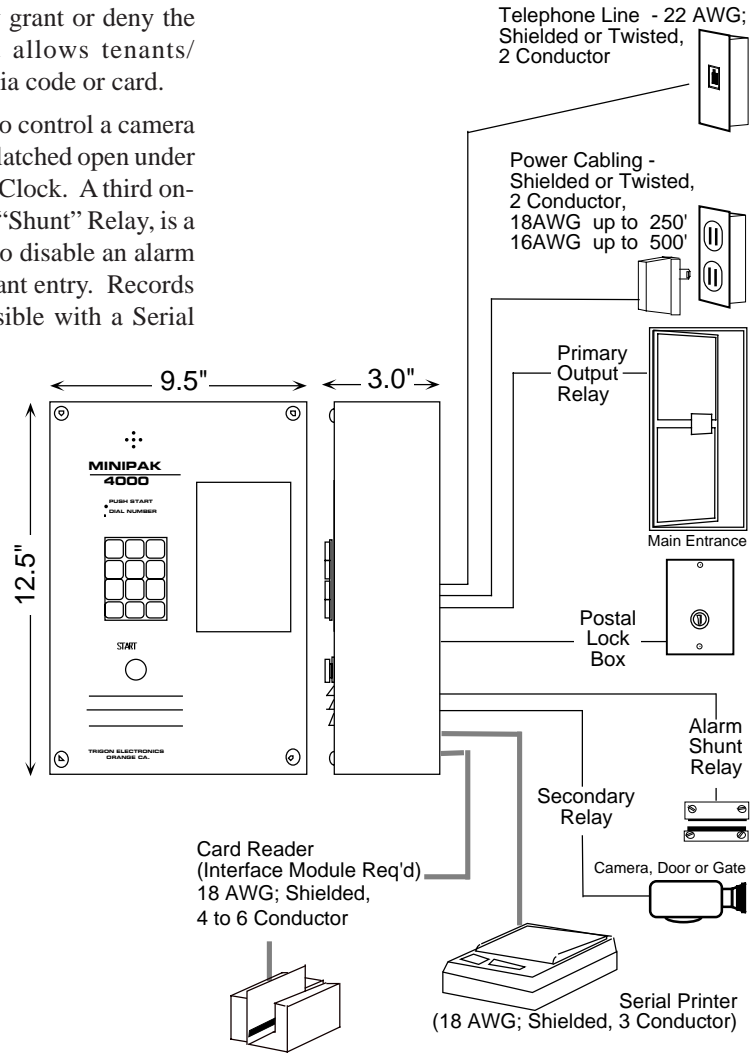

Figure 1

MOUNTING

The MP4000 may be connected to a no-phone-charge control switch such as the Trigon Model 5000, or connected to a dedicated telephone line. If connected to a dedicated telephone line, arrangements must be made with the local telephone company for installation of a standard voice-grade telephone line (Touch-tone or rotary), as close to the unit mounting location as possible. The telephone company may require the following information:

- FCC Registration No. ... AZ8898-62546-DT-I
- Ringer Equivalence 0.8B
- Connector Standard USOC Jack RJ-11-C

The unit is designed to be as weather-resistant as possible; however, we recommend some shelter from direct rain and sunlight. An overhang is usually sufficient.

Bolt the backplate to the mounting surface using the four 5/16" holes in the chassis. Also, feed the wiring through the access hole in the rear of the backplate. At this point, the wiring should NOT be energized.

It is critical on units that support a Liquid Crystal Display, that direct sunlight not be allowed to fall on the display itself. Like all Liquid Crystal Displays, heat absorption will temporarily blacken the crystals making the display unreadable.

If extreme cold is anticipated, a thermal switch and heater element may need to be installed inside the unit's housing. At about 20 degrees Fahrenheit, the display will become sluggish. If a heater element is installed, be sure to use a bimetal thermal switch to prevent overheating during the summer months.

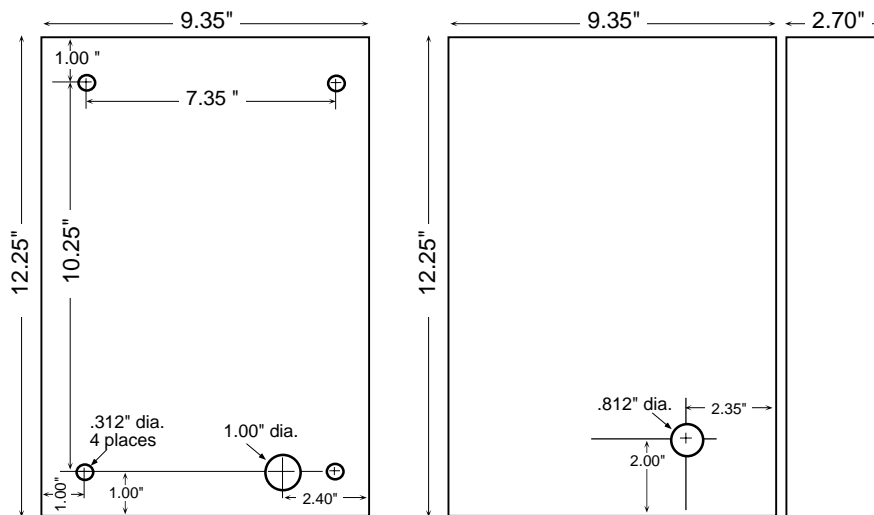

Figure 2

WIRING

1. Use the enclosed wiring diagram (Fig. 3) for wire connection information.
2. Do not power any other device from the Trigon's 12 VAC transformer. If a substitute transformer is used, be sure it is rated 12 VAC, 20VA, UL Class 2 listed. The 12 VAC input power wires should be 18AWG, 600V, insulated wire. This should be sufficient for distances up to 200 feet.
3. Do not energize wires until installation is completed.
4. Ground the unit by attaching a separate 12 AWG ground wire to the ground location on the terminal block. This ground wire should go to a grounding rod or grounded metal conduit.
5. Trigon recommends that an EMI filter (Cornell-Dubilier Model APF 1021 or equivalent) be mounted between the 12 VAC transformer output and the unit. EMI/RFI filters are available from Trigon. Mount the filter as close to the unit as possible. Ground the filter to the same point as unit ground.
6. Shielded cables recommended. Ground the shielding to the same point as the unit and filter. To avoid ground loops, do not ground the shield at both ends. Use 600V insulated wire for this installation.
7. Isolate the Telco line from 12 VAC power wires. This will prevent 60 Hz hum from occurring on the telephone line. Use 22 AWG wire on Telco line run distances of up to 2400 feet. Consult the factory for distances greater than 2400 feet.
8. Power Relays 1 and 2 are dry contact, Form C type, rated for 5 AMPS @ 30 VDC/ 250VAC.

WIRING (Continued)

9. The Shunt relay is a low-power (4 watt) reed relay. It can be used for temporary alarm switch bypass, video camera activation, etc. The Shunt relay activates with the #1 or #2 power relay, and deactivates thirty seconds after relay release when the power relay is activated by pressing 'O' or '8' on the resident's keypad.

10. Printer Operation (Option): The MP4000 supports audit log output to a remote serial printer up to 300 feet away.

The printer must be a SERIAL type with a standard RS232 interface connector. The settings of the printer are:

300 Baud, 8 bits, No parity, 1 stop bit.

Serial linkage requires a minimum of three wires that carry "DATA, COMMON, and BUSY".

The logic board has three terminals marked:

1. "COM" which goes to pin 7 (Com) of a printer RS232 port.
2. "OUT" which goes to pin 3 (Rec. Data) of a printer RS232 port.
3. "BSY" which goes to pin 20 (Transmit Data) of a printer RS232 port.

All access data is recorded to the printer.

11. Postal Input: Two screw terminals are located on the logic board marked "POST". Shorting these terminals together via the Postal Switch will cause the unit to generate a Gate Open Cycle and generate a Postal Access message to Audit Log.

NOTE: Other forms of emergency access may also use this input but will be logged as Postal Entry granted.

12. If all wiring and grounding is completed, mount the faceplate onto the backbox.

Telephone Line/Cabling
Voice Grade, 24 to 48VDC 22 AWG; Shielded or twisted up to 2400'.

Input Power Cabling	
0 - 250'	18 AWG; Shielded
250 - 500'	16 AWG; Shielded

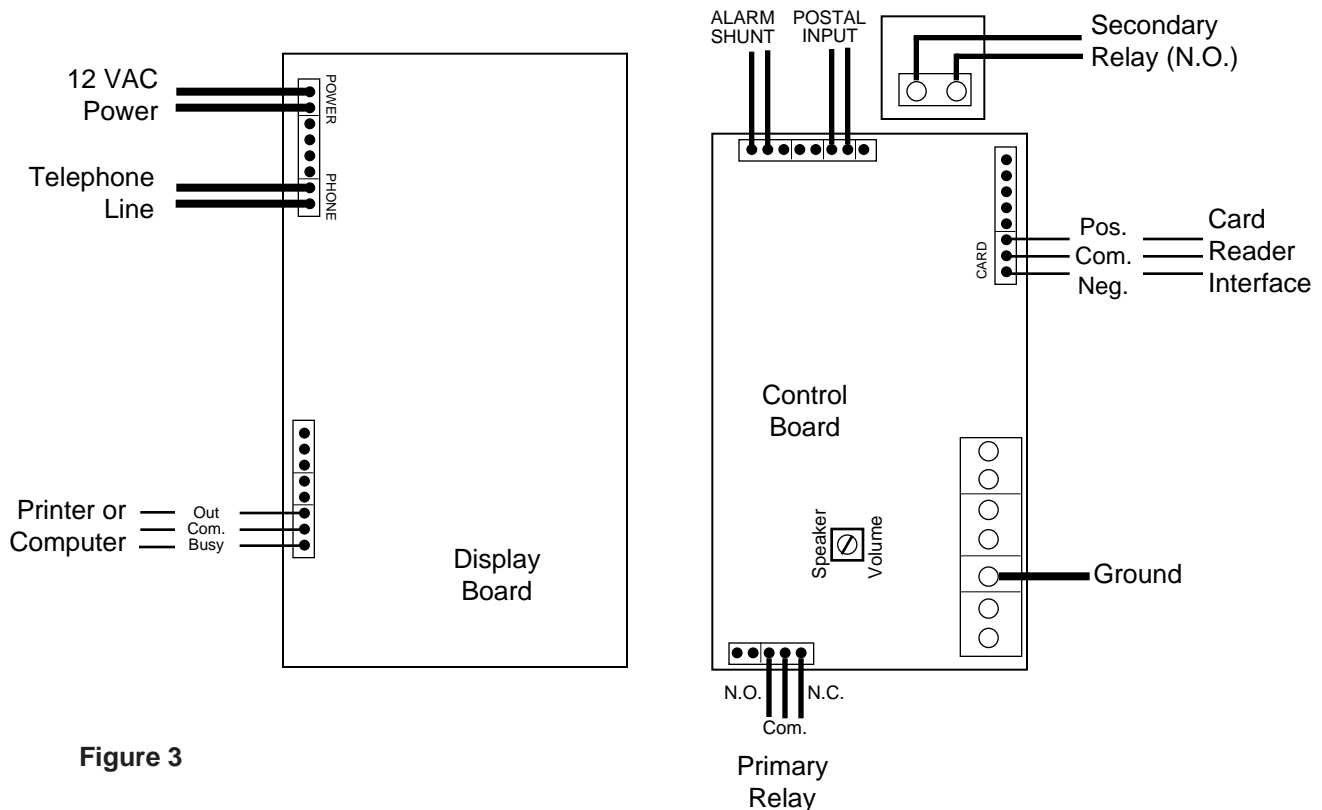

Figure 3

PROGRAMMING

Note: The Model MP4000 can be locally programmed via the unit's keypad or remotely programmed via a Hayes Compatible 1200 baud modem.

The following instruction refer to programming the Model MP4000 directly from the unit's keypad. For remote programming instructions, see Trigon's PSL4000 product support software and it's instructions.

ENTER PROGRAM MODE:

Before any programming can be done, you must first enter the Program Mode. Begin by pressing the start button for dial tone. Enter "*" and the unit's Program Code. (The code is 5269 if unit is new). The first screen to appear is the 'Setup' Screen. It will display the following format:

Figure 4

```

      SETUP SCREEN
      * = SKIP SCREEN
      # = CURSOR DOWN
      0 = CHOICES
      >[4] RES.LENGTH
      [3] RING COUNT
      [3] GATE TIME
      [3] CALL LENGTH
      [T] DIAL MODE
      [N] ACT. KEYPAD
      [4] WELCOME SEC
      [8] INSTRCT SEC
      [N] SET INVERSE
      [N] DENSE MODE

```

SETUP SCREEN

If you are installing the unit and are ready to begin programming, it is necessary for you to do Setup first.

If the unit is already installed and in service, Setup may not be necessary. However, if you wish to change Setup parameters, you may do so.

You may find it helpful to read through SETUP before actually performing any of the steps.

NOTE: Characters inside brackets in Figure 1 represent factory presets.

If you press the '*' key at this time, you will leave this screen and go to Screen 2.

If you press the '#' key, you will move the Cursor (>) down one line.

Pressing the '0' key will cause the character within the brackets beside the Cursor to step through the choices for that particular Setup parameter.

DEFINITIONS

RES. LENGTH:

"Resident Code Length" refers to the number of digits the visitor will have to dial to call a tenant. For example: Apartment "304" is three digits. To call Apt. 304, one would dial "3, 0, 4". Resident Codes can be from 1 to 4 digits in length. Select the digit (1-4) that corresponds to the desired Resident Code length for all tenants.

RING COUNT:

"Ring Count" refers to the number of incoming rings the MP4000 will wait before it auto-answers. This count is adjustable from 1 to 9. Select the digit (1-9) that corresponds to the desired ring count.

GATE TIME:

"Gate Time" refers to the length of time Relay 1 or 2 will stay engaged after an "Activate Relay" command has been issued.

One gate interval equals five seconds. You may set the total gate interval time by selecting the digit that corresponds to the number of five-second gate intervals desired. For example: Select "6" for six 5-second intervals (30 seconds). Select the digit (1-9) that corresponds to the total number of gate intervals desired.

NOTE: A "0" will allow Relay 1 or 2 to engage for a one second pulse.

CALL LENGTH:

"Call Length" refers to the maximum time (in minutes) that the unit will allow a conversation to last. Select the digit (1-4) that corresponds to the Call Length time (in minutes) that is desired.

NOTE: A "0" allows indefinite Call Length, however the unit will auto-disconnect after 30 seconds of voice silence.

DIAL MODE:

"Dial Mode" refers to the type of signal the unit uses to dial a telephone number. The MP4000 is capable of dialing Touch-tone or rotary/pulse. Select "T" if Touch-tone is desired, or select "R" for rotary/pulse dial out.

Programming (Continued)

ACT. KEYPAD:

“Active Keypad” allows the keypad to be used for stepping through “voice-mail”, paging systems, etc. Select ‘N’ for NO, NOT Active Keypad or ‘Y’ for YES, Active Keypad. The keypad is Active only after tenant connection has been established.

WELCOME SEC

This selection allows you to choose the length of time that the ‘WELCOME’ message stays displayed (in seconds). Select the digit (0-9) that corresponds to the number of seconds that you wish for this message to be displayed.

INSTRCT SEC

This selection allows you to choose the length of time that the ‘INSTRUCTION’ message stays displayed (in seconds). Select the digit (1-9) that corresponds to the number of seconds for this message to be displayed.

SET INVERSE

This function allows you to choose between Normal display and Inverse display. Normal is white characters on a black background, and Inverse is the opposite. Select ‘N’ for NO, NOT Inverse or ‘Y’ for YES, Inverse.

DENSE MODE

“Dense Mode” sets the number of listings displayed per screen. Normal Mode displays up to 15 listings per screen, while Dense Mode displays up to 29 listings per screen. Select ‘N’ for NO, NOT Dense Mode or ‘Y’ for YES, Dense Mode.

CLOCK CONTROL SCREEN

The second screen in the Program Mode is the ‘Clock Control’ screen. It will display the format shown in Figure 5.

If you press the ‘*’ key at this time, you will leave this screen and go to Screen 3, Message Edit..

If you press the ‘#’ key, you will move the Cursor (>) down one line.

The numeric keys (0-9) are used to complete the required data inside the brackets next to the Cursor.

SET CURRENT DATE AND TIME

The first six lines require the current Date and Time. ‘HOURS’ are expressed in Military time based on the 24 hour clock. ‘DAY’ refers to the day of the week; Monday being Day 01 through Sunday, Day 07.

```

CLOCK CONTROLS
* = SKIP SCREEN
# = CURSOR DOWN
0-9 CHANGE
>[11] MONTH
[11] DATE
[99] YEAR
[04] DAY
[15] HOURS
[59] MINUTES
[00] #1 ON HR
[00] #1 ON MIN
[00] #1 OFF HR
[00] #1 OFF MIN
[00] #1 DAY/DAY
[00] #2 ON HR
[00] #2 ON MIN
[00] #2 OFF HR
[00] #2 OFF MIN
[00] #2 DAY/DAY
[00] LP ON HR
[00] LP ON MIN
[00] LP OFF HR
[00] LP OFF MIN
[00] LP DAY/DAY
[52] ACCESS MSD
[69] ACCESS LSD

```

Figure 5

SET RELAY, BACKLIGHT ON/OFF TIMING

The next groups of parameters are used to control the automatic timing of Relays #1 and #2, as well as the Display Backlight ON and OFF timing.

Suppose we wish to leave the door unlocked between the hours of 7:30 AM and 5:00 PM on Monday through Friday. The Door Strike is wired through Relay #1. We would program the display to show the following:

```

[07] #1 ON HR
[30] #1 ON MIN
[17] #1 OFF HR
[00] #1 OFF MIN
[15] #1 DAY/DAY

```

The fifth parameter in this example [15], relates to day 1 through day 5, (Monday through Friday).

If you wish to extend the life of the lamp used to Backlight the Display, the lamp can be programmed to automatically shut off during low traffic hours. If the unit senses activity on its keypad, the lamp will come back on for a limited period of time.

Programming (Continued)

SET PROGRAM CODE

The last two lines on this screen are used to set the Program Code for this unit. One line contains the first two digits of the code (MSD), and the next line contains the last two digits (LSD).

NOTE: If, after performing this step, you lose the ability to access the Program Mode, call TRIGON service. We have the ability to reset the Program Code back to 5269 remotely.

MASTER ERASE

To clear all files from memory as well as return Setup parameters to factory presets, set Program Access Code to 9999. This will erase all data and reset the Program Access Code to 5269.

MESSAGE EDIT SCREEN

The next screen to appear in the Program Mode is the 'Message Edit' Screen. This screen is used to create your own message to be displayed as the 'WELCOME' Screen. It will display the following format:

Figure 6

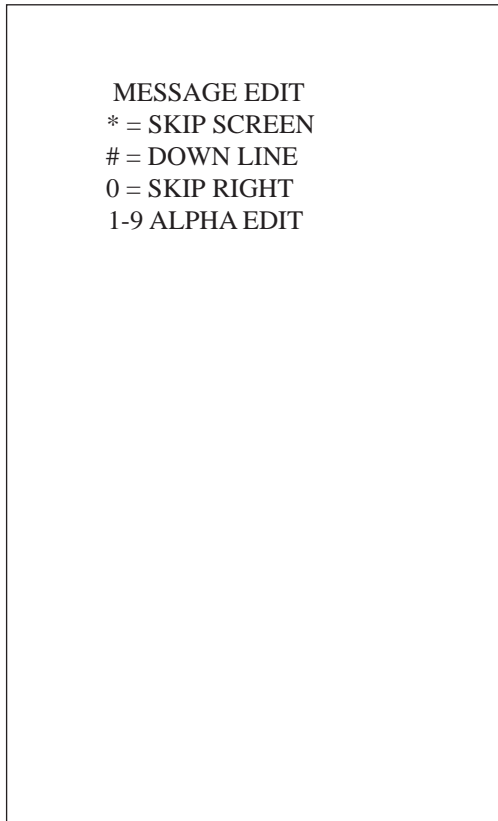

message. Each character is made with two keystrokes. For example, to create an "A", press 2, then 1. The 2 represents the key the 'A' letter is located on, and 1 represents the fact 'A' is the first letter on the key. To make a "B", press 2, 2. Again, 'B' is on the '2' key, its second letter. Spaces are made by pressing 1, 1. The letter 'Q' is 1, 2. The letter 'Z' is 1, 3. Press "#" to go to the next line. Press the star key (*) to go back. See the DISPLAY EDITING section for more information.

If you wish to eliminate the Message Edit screen, set the 'WELCOME SEC' parameter to '0' on the Setup Screen.

DATABASE EDIT SCREEN

The last screen to appear in the Program Mode is the 'Database Edit' Screen. This is the screen that will be used for all keypad editing of tenant information. It will display the following format:

Figure 7

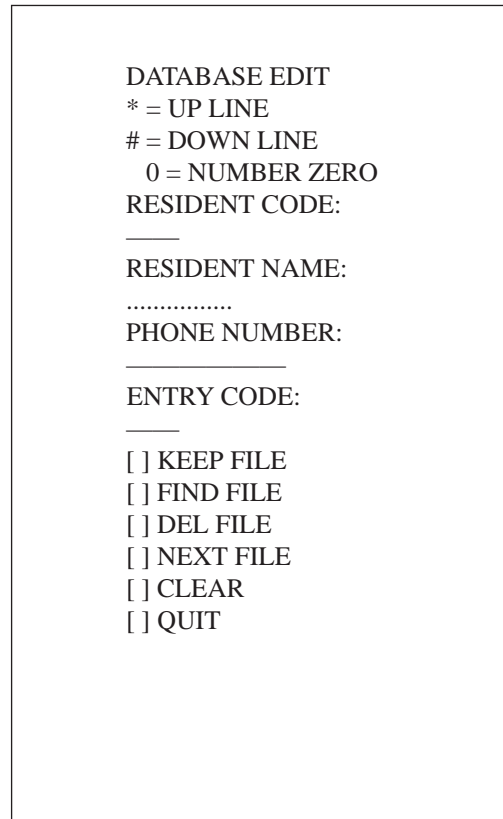

There are 12 lines available on this screen for your message. Each line will hold 16 characters or spaces. Alphabetic characters are entered from the keypad to the 'Message Edit' screen in order to create a custom

Programming (Continued)

RESIDENT CODE

To program a listing for the electronic directory, first assign a RESIDENT CODE for that tenant. Only ONE listing is allowed for each RESIDENT CODE. All entries in that field will be numeric. Enter a RESIDENT CODE now.

RESIDENT NAME

Press the '#' key to move the Cursor to the RESIDENT NAME line. The '0' line at the top of the screen will change to read: "0 = SKIP RIGHT". Enter the RESIDENT NAME now. Each character is made with two keystrokes. For example, to create an "A", press 2, then 1. The 2 represents the key the 'A' letter is located on, and 1 represents the fact 'A' is the first letter on the key. To make a "B", press 2, 2. Again, 'B' is on the '2' key, its second letter. Spaces are made by pressing 1, 1. The letter 'Q' is 1, 2. The letter 'Z' is 1, 3. Press "#" to go to the next line. Press the star key (*) to go back. Press '0' to skip over and leave in place a period. See the DISPLAY EDITING section for more information.

Note: The name can be up to 16 digits in length, however the last characters of a long name may be covered up by the RESIDENT CODE on a Directory listing. Only alphabetic characters may be entered on this line.

PHONE NUMBER

Press the '#' key to move the Cursor to the PHONE NUMBER line. The '0' line at the top changes back to read: "0 = NUMBER ZERO". Enter the PHONE NUMBER for this tenant now. The phone number can be up to 12 digits in length. All entries in this field will be numeric.

ENTRY CODE

Press the '#' key to move the Cursor to the ENTRY CODE line. Enter the 4-digit ENTRY CODE now. If just one ENTRY CODE will be assigned for all tenants, it should be stored at one tenant location only. This makes it easier to change the code later. The ENTRY CODE must be 4 digits in length. ENTRY CODES that begin with a '9' will close the Secondary Relay. All data in this field is numeric.

ENROLL ACCESS CARDS

Access cards may also be enrolled using the Entry Code function. (Requires the unit be equipped with the optional interface module and a card reader.) With the cursor positioned at the first entry code digit location,

use the desired card at the attached card reader. The card number will be read into the entry code location.

Press the '#' key to move the Cursor down one line. The '0' line at the top changes to read: "0 = PERFORM JOB". This means that the function listed beside the current Cursor location will be performed when the '0' key is pressed.

The Cursor should now be inside the brackets beside the line that reads: "KEEP FILE". Press the '0' key to store the file that was just created.

"FIND FILE" is used to locate a tenant file in memory. When a RESIDENT CODE is entered, FIND FILE will display all data associated with that RESIDENT CODE.

"DEL FILE" will delete from memory, the current file that is displayed at the top of this screen.

"NEXT FILE" will step through the files in memory in the order in which they were entered.

"CLEAR" will remove the file data from this screen, but will not remove it from memory.

"QUIT" will take you out of Program Mode and return to Normal Mode.

TENANT FILE EDITING

To change data pertaining to a tenant, first enter the tenant's RESIDENT CODE in the RESIDENT CODE field. Next move the Cursor to the line labeled: 'FIND FILE' and press the '0' key. The screen will display the data for that tenant. Any information pertaining to that tenant may now be changed by moving the Cursor to the relevant field and writing over the existing data. When all corrected data has been entered, move the Cursor to 'KEEP FILE' and press the '0' key. The updated file will be stored in memory.

If the RESIDENT CODE is not known for a particular piece of data, such as ENTRY CODE, use the 'NEXT FILE' command to step through the listings in memory.

DISPLAY EDITING

To EDIT is to REPLACE. Editing replaces blank spaces on the Message Screen and periods on the Database Edit Screen with a desired letter, space, or period (as in "SMITH J").

NOTE: There are no periods on the Message Screens.

Each letter is selected with two (2) key strokes on the keypad.

When a listing is complete, use '#' to move the Cursor to the next line.

The two letter keystroke combinations are:

NOTES:

'Q' and 'Z' are located on key '1' (not seen).

Key in '11' to SPACE the Cursor 1 position to the right.

Key '0' is used for nondestructive Cursor Skip Right.

Key '*' is BACKUP one line.

Key '#' is GO DOWN one line.

To get the PERIOD in 'SMITH J.' use nondestructive skip, '0' to leave the existing '.' in place after the letter 'J'.

From the keypad editor, only "A" through "Z", SPACE, and preexisting PERIODS are possible.

Use key sequence "11" to erase a position (SPACE over).

Use keypad sequence "#*" to restore Cursor to the first position of any given listing.

Alphabetizing is automatic, based on the first letter of each listing.

Look at this Example:

To Enter: S M I T H J.

The letter 'S' is on the '7' key of a Telephone Keypad.

. PRESS 7.

(This limits the selection to three choices; 'P R S'). Note that 'S' is the third (3rd) letter on that key.

. PRESS 3.

An 'S' will now appear and the Cursor will move right to the next position.

Letter 'M' is on key '6' Position 1,

PRESS 61

Letter 'I' is on key '4' Position 3,

PRESS 43

Letter 'T' is on key '8' Position 1,

PRESS 81

Letter 'H' is on key '4' Position 2,

PRESS 42

Space ' ' is on key '1' Position 1,

PRESS 11

Letter 'J' is on key '5' Position 1,

PRESS 51

Symbol '.' is displayed so use a single '0' to skip over.

Use '11', '11', '11', etc. to replace the rest of the periods on that line with active SPACES.

Figure 8

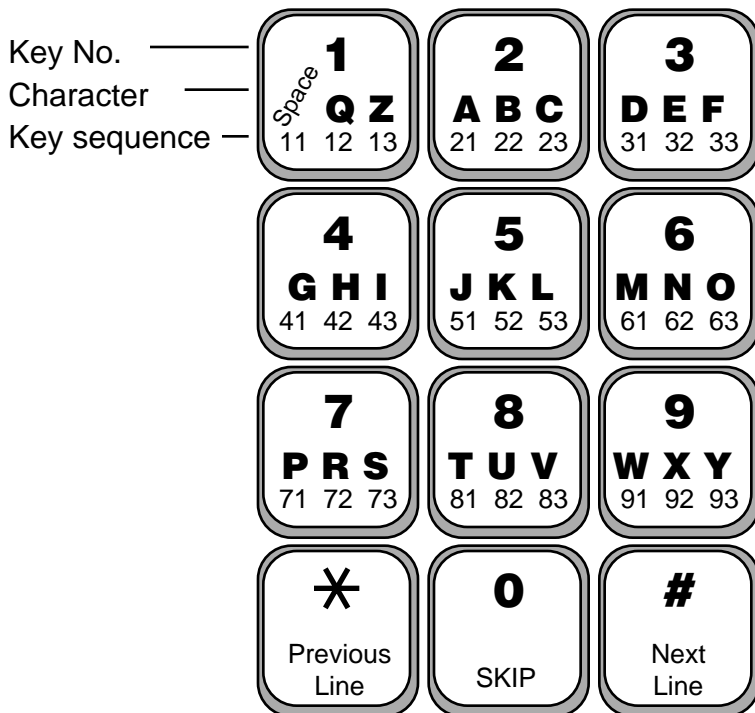

OPERATION

Calling a Tenant:

Building Information and Guest Instructions are displayed on the MP4000 front panel and screen.

Press the start button for dial tone. Enter the Resident Code located next to the tenant's name on the directory. You should hear the tenant answer and be able to converse with them.

Direct Entry Codes:

Press the start button for dial tone. Enter “#” and your four digit Entry Code.

Letting a Visitor In:

Answer telephone and identify visitor. You have the following options:

Touch-tone Telephones

Enter “0” to activate Relay 1 and disconnect.

Enter “8” to activate Relay 2 and disconnect.

Enter “9” to activate Relay 2 and continue conversation.

Rotary Telephones

Dial “0” to activate Relay 1 and disconnect.

Denying Visitor Entry (disconnect):

To deny entry, enter “7” to force disconnect. Hang up telephone.

Note: It is important that the tenants recognize this responsibility because otherwise the visitor will walk away leaving the unit active. Shortly, an off-hook indicator tone from the phone company will be loudly heard for the remaining call length.

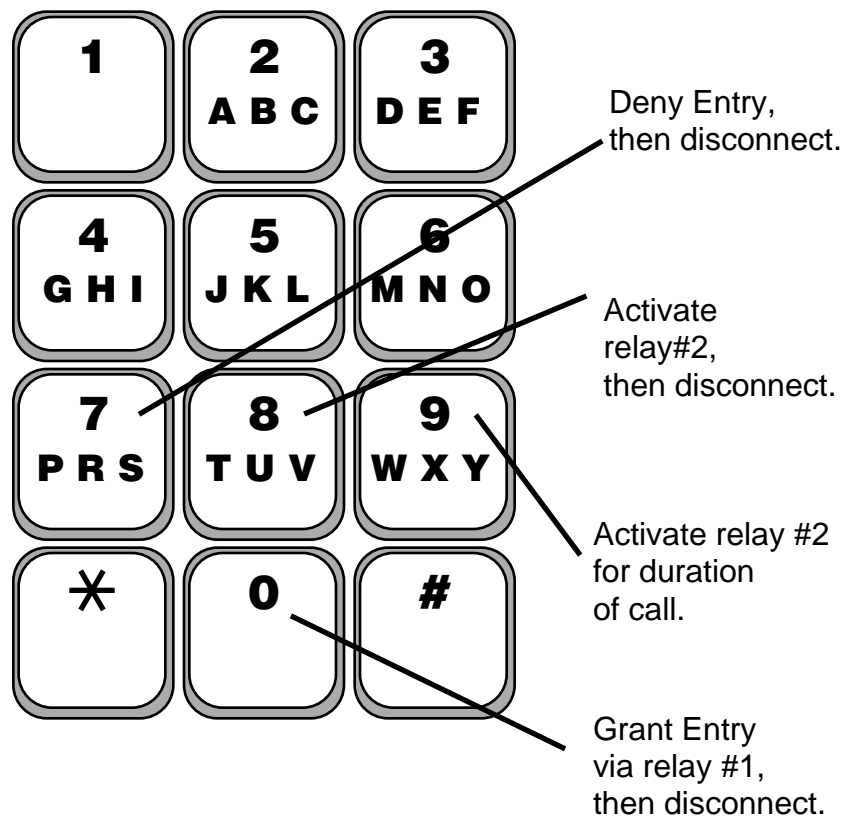

Figure 9

Troubleshooting Guide

NO DIAL TONE

1. Check input power at unit. Should be 12 VAC. Check fuse.
2. Check that unit is properly grounded to a good Earth ground.
3. Current starved. Increase AC input wire size.
4. Remove power, wait 5 seconds, restore power. Check for dial tone.
5. Check for phone line. Should be 48-52 VDC across phone line terminals (on hook).
6. Check VOLUME adjustment on PC board.
7. Check "SPKR" plug on PC board. Make sure speaker is properly plugged in.
8. Verify that contacts and wires are clean and tight.

CANNOT PROGRAM

1. Incorrect/lost program code.
2. Not entering "*" before program code.
3. Try 'NO DIAL TONE' troubleshooting procedures.
4. Not pressing start button before entering code.
5. Keypad damaged. Check for vandalism.
6. Check that Program Prom/Microprocessor is fully seated.

LOSES MEMORY

1. Electrical noise on power line. Install EMI/RFI filter.
2. Excessive electrical noise from strike. Use low current strike.
3. Unit transformer shared with another device (i.e. door strike).

UNIT NOT DIALING

1. No phone number programmed under that resident code. Reprogram and try again.
2. Incorrect resident code length entered (see SETUP).
3. Unit dialing Touch-tone on a rotary telephone line.
4. Check phone line at board terminals. Should be 48-52 VDC (on hook).
5. If on an in-house phone system, incorrect dialing procedure to access outside line/extension. May require special software.
6. Low AC Supply voltage or incorrect/defective transformer.

TENANT CANNOT ACTIVATE STRIKE/GATE

1. Tenant not pressing correct number on telephone.
2. Strike/gate operator not wired correctly.
3. Missing or incorrect power to strike or gate operator.
4. Current starved. Increase wire size.
5. Tone may be too brief in duration (cordless phones, etc.).

AC HUM IN EARPIECE/SPEAKER

1. Telephone wires running in same conduit as AC power.
2. Unit not properly grounded.
3. Defective microphone.

TENANT CANNOT HEAR VISITOR

1. Defective microphone.
2. Too much background or street noise. Relocate unit.