

# Miniguard HS-2

## Handset Telephone Entry Autodialer



### INSTALLATION and OPERATIONAL INSTRUCTIONS

with 10 number rollover



255 Glider Circle Corona, CA 92880  
(800) 842-7444 [Info@trigonelectronics.com](mailto:Info@trigonelectronics.com)

[www.TrigonElectronics.com](http://www.TrigonElectronics.com)

March 1, 2004

---

**TABLE OF CONTENTS**

---

<b>INTRODUCTION</b> .....	3
<b>PRODUCT OVERVIEW</b> .....	3
<b>MOUNTING</b> .....	4
<b>WIRING</b> .....	4
<b>WIRING DIAGRAM</b> .....	5
<b>PROGRAMMING</b>	
Entering Program Mode .....	6
Setting Operational Modes .....	6
Entering Autodialed Telephone Numbers .....	6
Verifying Autodialed Telephone Number .....	6
Setting the Site ID Number .....	7
Changing Program Access Number .....	7
Setting the Relay Duration Timer .....	7
Setting Incoming Ring Count .....	7
Setting Dial Mode .....	7
Setting Call Length .....	7
DTMF Echo Test .....	7
Cycling Relays .....	7
<b>OPERATION</b>	
<b>STANDARD</b> Mode .....	8
<b>EMERGENCY</b> Mode .....	8
<b>TROUBLE SHOOTING GUIDE</b>	
General .....	9
<b>CONDENSED GUIDE TO USE and PROGRAMMING</b>	
Security Dept. Operation .....	10
Standard Mode .....	10
Emergency Mode .....	10
Programming the Unit .....	10

## INTRODUCTION

This manual contains all the information required to install and program the TRIGON HS-2. If you are using this manual to install this unit, it is very important to read all the sections in order.

You should read these instructions before you begin installation. This will insure that everything is done efficiently.

If you are using this manual as a programming guide after the initial installation, you may find the TABLE OF CONTENTS useful in locating the particular programming procedure you need.

## PRODUCT OVERVIEW

The TRIGON HS-2 is a multi-number auto dialer. Upon Lifting the handset, the HS-2 dials a programmed telephone number. If the number dialed is busy or does not answer, the HS-2 will hang up and dial the next programmed number, up to a maximum of 10. If the last programmed number is busy or does not answer, the HS-2 will rollover and start the dialing process again with the first phone number.

The HS-2 comes standard with 2 output relays. These relays can be programmed to operate in several different ways. Relays can be set to pulse momentarily for camera call-up, they can be set to stay latched on for the duration of the call, or they can be set to operate for a timed duration (for door strike operation, etc).

There are two Modes of Operation incorporated in the HS-2:

1. The **Standard Mode** provides timed closure of the relays and is typically used for access control.
2. The **Emergency Mode** causes relay activation at the moment the start button is pressed. This mode is best suited for safety use when camera and lighting control is desired.

A Site I.D. code feature provides for unit identification. The Site I.D. code is a programmable four digit code that is transmitted by the HS-2 when it receives a command from the called party. This code, when interpreted by a Trigon DTMF Decoder, will identify the calling unit.

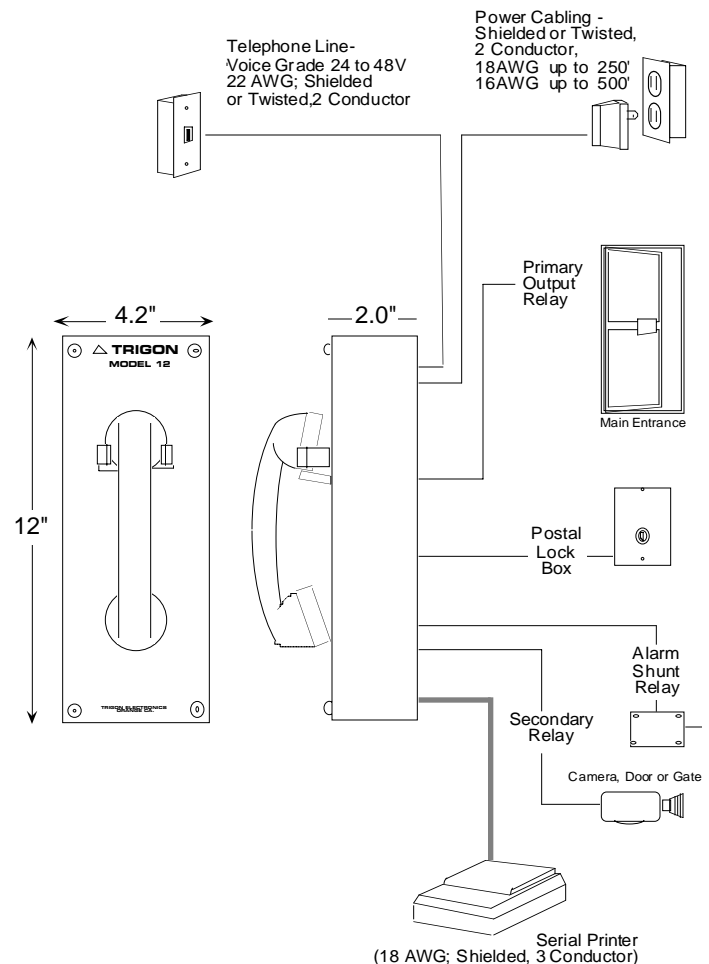
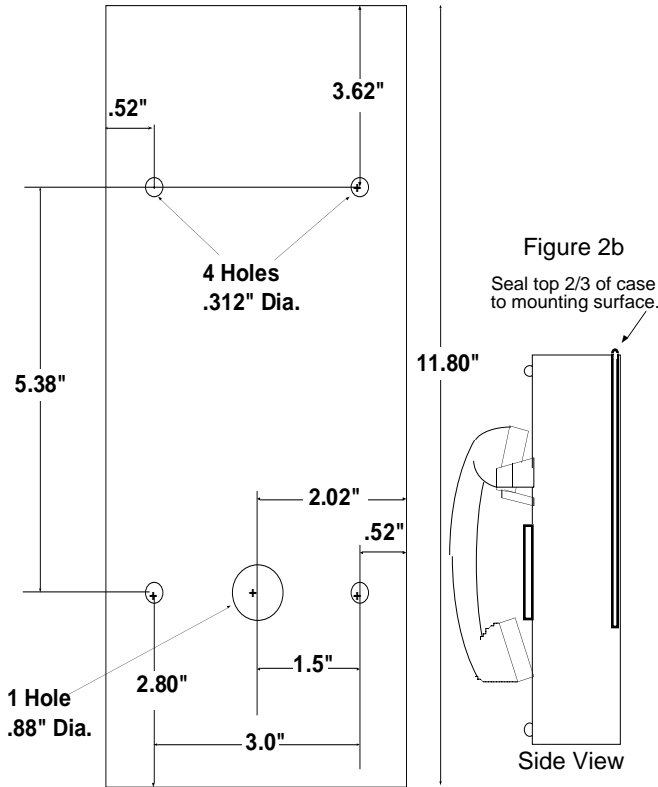

Figure 1

**MOUNTING**



**Note:** Mount backplate with 1" wire entry hole toward the bottom. Seal the opening with a silicone sealant before attaching backplate to surface.

**Figure 2**

Arrangements must be made with the local telephone company for installation of a standard voice-grade telephone line (touch-tone or rotary) as close to the unit mounting location as possible. The telephone company may require the following information.

FCC Registration No.....1Z8898-62546-DI-T  
 Ringer Equivalence.....0.8B  
 Connector.....Terminal Block

The unit is designed to be as weather resistant as possible. We do however recommend some shelter from direct rain and sunlight. An overhang is usually sufficient. Bolt the back plate (**Fig. 2**) to the mounting surface using the four .312" holes in the chassis. Feed the wiring through the access hole in the rear of the back plate. At this point, the wiring should NOT be live (energized).

**Note:** If used in extreme weather, a bead of silicon sealant should be run around the outside top two thirds of the unit, after the front case is secured.

(Fig. 2b).

**WIRING**

1. Use the wiring diagram (Fig. 3) for wire connection information.
2. Do not power any other device from the Trigon's 12 VAC transformer. If a substitute transformer is used, be sure it is rated 12 VAC, 40VA, UL Class 2 listed. The 12 VAC input power wires should be 18AWG, 600V, insulated wire. This should be sufficient for distances up to 200 feet.
3. Do not energize wires until installation is completed.
4. Ground the unit by attaching a separate 12 AWG ground wire to the ground location on the terminal block. This ground wire should go to a grounding rod or grounded metal conduit.
5. Trigon recommends that an EMI filter (Cornell-Dubilier Model APF 1021 or equivalent) be mounted between the 12 VAC transformer output and the unit. EMI/RFI filters are available from Trigon. Mount the filter as close to the unit as possible. Ground the filter to the same point as unit ground.
6. Shielded cable is recommended. Ground the shielding to the same point as the unit and filter. To avoid ground loops, do not ground the shield at both ends. Use 600V insulated wire for this installation.
7. Isolate the Telco phoneline from 12 VAC power wires. This will prevent 60 Hz hum from occurring on the phoneline. Use 22 AWG wire on Telco line run distances of up to 2400 feet. Consult the factory for distances greater than 2400 feet.
8. Power Relays 1 and 2 are dry contact, Form C type, rated for 5 AMPS @ 30 VDC/ 250VAC.
9. The Shunt relay is a low-power (4 watt) reed relay. It can be used for temporary alarm switch bypass, video camera activation, etc. The Shunt relay activates with the #1 or #2 power relay, and deactivates thirty seconds after relay release.
10. Connect printer wiring to the RS-232 port (Printer IN to RS-232 OUT, Printer BUSY to RS-232 DSR, Printer COM to RS-232 COM).
11. If all wiring and grounding is completed, mount the faceplate onto the backbox.

**WIRING DIAGRAM**

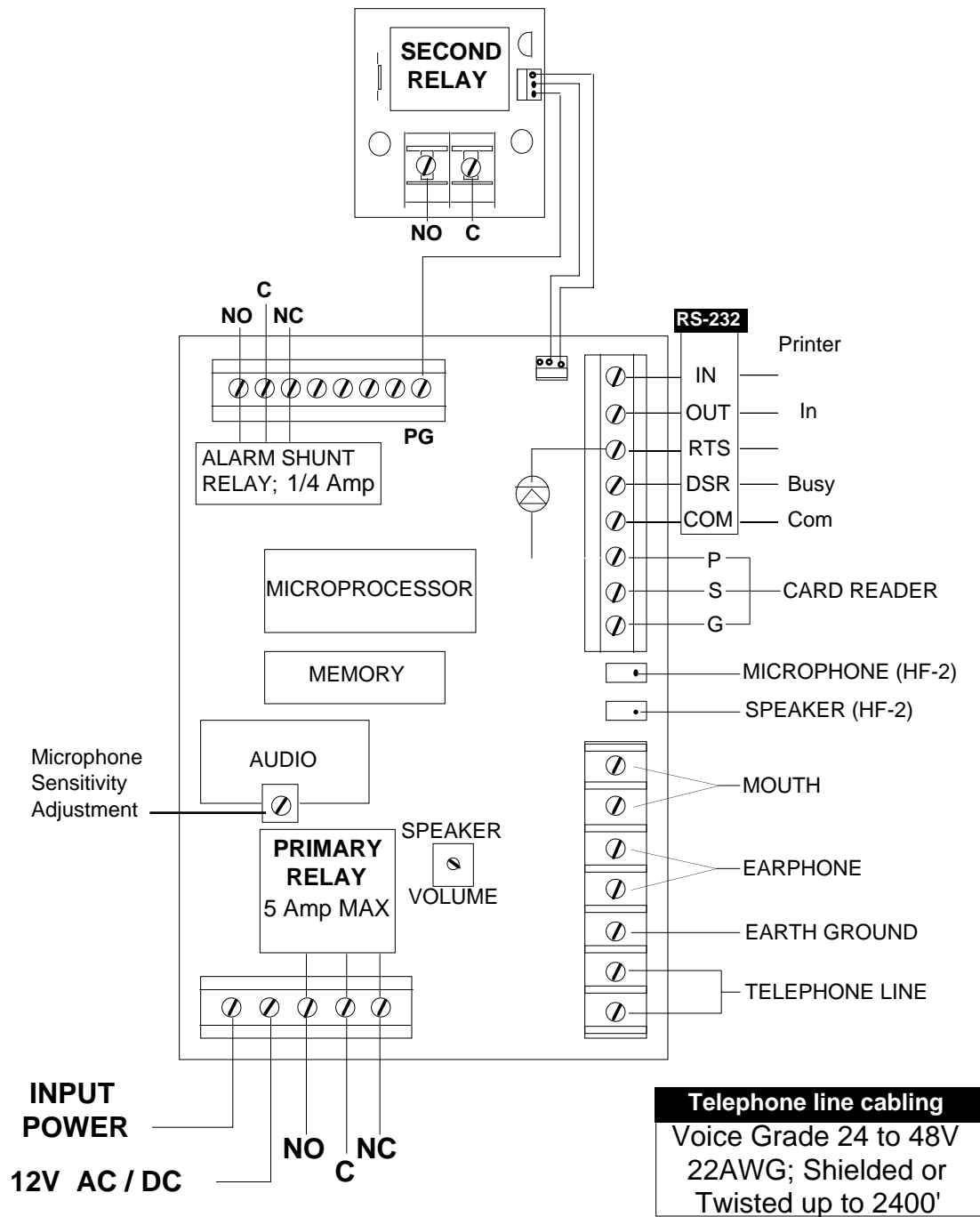

Input power cabling	
0-250'	18 AWG; Shielded
250 to 500'	16 AWG; Shielded
500' +	14 AWG; Shielded

Figure 3

**General Programming Information**

The "Initial Setup" for the HS-2 has been programmed at the factory. These factory default settings may be changed to better suit your particular application. If you decide to alter these settings, follow the instructions below. It is important that each programming step be taken in order. When reprogramming a specific feature, you must always enter the programming mode first. You may then go to the appropriate procedural steps for the changes desired.

Record below the autodialed numbers to be programmed into the HS-2.

**Autodialed Numbers**

**Primary Auto dial Number (16 digit max)**

\_\_\_\_\_

**Second Auto dial Number (16 digit max)**

\_\_\_\_\_

**Third Auto dial Number (16 digit max)**

\_\_\_\_\_

**Fourth Auto dial Number (16 digit max)**

\_\_\_\_\_

**Fifth Auto dial Number (16 digit max)**

\_\_\_\_\_

**Sixth Auto dial Number (16 digit max)**

\_\_\_\_\_

**Seventh Auto dial Number (16 digit max)**

\_\_\_\_\_

**Eighth Auto dial Number (16 digit max)**

\_\_\_\_\_

**Ninth Auto dial Number (16 digit max)**

\_\_\_\_\_

**Tenth Auto dial Number (16 digit max)**

\_\_\_\_\_

**Site ID Number-if required Number (4 digits)**

\_\_\_\_\_

**PROGRAMMING**

**(A) To Enter Program Mode:**

1. Call the telephone number of the unit.
2. Listen for the two second tone.
3. Enter '\*' then the unit's Program Code.
4. If desired, exit Program Mode by pressing '#' (wait for two second tone).
5. To terminate call, press '7'.

If the unit is new, use the preset factory code. **(Factory code is 9753).**

**Note:** If the unit has been changed to the Emergency Mode, use '#' instead of '\*' to enter program mode.

**(B) Setting Operational Modes:**

**These settings determine how the HS-2 relays will function.**

Except when noted, each of the following program commands will result in two (2) tones (high/low) signifying their completion and acceptance.

*Standard Mode* allows the relays to be activated for a specified time period (such as for access control purposes).

1. Unit must be in Program Mode.
2. Press '7' then press '0' to set unit for standard mode.
3. If desired, exit Program Mode by pressing '#' (wait for two second tone).
4. To terminate call, press '7'.

*Emergency Mode*, causes one relay to be momentarily activated when a call is placed (for camera call-up) while the other relay activates continuously throughout the call (for lighting, etc.).

1. Unit must be in Program Mode.
2. Press '7' then press '1' to set unit for Emergency Mode.
3. If desired, exit Program mode by pressing '#' (wait for two second tone).
4. To terminate call, press '7'.

**(C) Setting the Primary and Backup Telephone Numbers:**

1. Unit must be in Program Mode.
2. Press '2' then '1' (wait for tone) and enter the first phone number. Press '#' when complete. Press '2' then '2' (wait for tone) and enter the second phone number. Press '#' when complete. If more numbers are needed press '2' then '3' (wait for tone) and so on for up to 10 phone numbers. Press '#' when complete.
3. If desired, exit Program Mode by pressing '3' (wait for two second tone).
4. To terminate call, press '7'.

**(D) Verifying Telephone Numbers:**

1. Unit must be in Program Mode.
2. Press '\*' then press '1' to verify the first phone number entered.
3. Press '\*' then press '2' to verify the second phone number entered etc.
4. If desired, exit Program Mode by pressing '#' (wait for two second tone).
5. To terminate call, press '7'.

## PROGRAMMING, Cont.

### (E) Setting the Site ID Number:

This number identifies the unit upon request from a central office.

1. Unit must be in Program Mode.
2. Press '1'.
3. Enter a four digit number.

You will hear two 'beeps' indicating command accepted.

4. If desired, exit Program Mode by pressing '#' (wait for two second tone).
5. To terminate call, press '7'.

### (F) Changing Program Access Number:

This will change the factory preset number of '9753'.

1. Unit must be in Program Mode.
2. Press '3'.
3. Enter a new four digit number.

You will hear two 'beeps' indicating command accepted.

4. If desired, exit Program Mode by pressing '#' (wait for two second tone).
5. To terminate call, press '7'.

### (G) Setting the Relay Duration Timer:

This will set the length of time the Primary and Secondary relays remain activated. The duration can be set from 1 to 45 seconds.

The duration is set by entering the number of five-second intervals desired (2= ten seconds).

1. Unit must be in Program Mode.
2. Press '0'.
3. Enter the number of 5 sec. intervals required.

You will hear two 'beeps' indicating command accepted.

4. If desired, exit Program Mode by pressing '#' (wait for two second tone).
5. To terminate call, press '7'.

**Note:** If '0' is entered in step 3, relays will pulse for one second.

### (H) Setting Incoming Ring Count:

Entering a digit value of 1 to 9 will set the number of rings the unit will count before answering an incoming call.

1. Unit must be in Program Mode.
2. Press '5'.
3. Enter the number of rings desired ( 1 to 9).

or

4. Enter '0' if an audible ring is desired from the HS--2 whenever it is called.

You will hear two 'beeps' indicating command accepted

5. If desired, exit Program Mode by pressing '#' (wait for two second tone).

6. To terminate call, press '7'.

**Note:** If '0' was programmed for an audible ring, the call may be answered by pressing the first 'Call' button on the face of the unit.

### (I) Setting the Dial Mode.

This will select Rotary or Touch-Tone dialing.

1. The unit must be in Program Mode.
2. Press '6'.
3. Press '1' for Rotary.  
or
4. Press '0' for Touch-Tone.

You will hear two 'beeps' indicating command accepted

5. If desired, exit Program Mode by pressing '#' (wait for two second tone).
6. To terminate call, press '7'.

**Note:** Adding 2 to the above value will result in the Secondary relay closing for three seconds at dial time.

### (J) Setting Call Length:

This is the period of time allowed for conversation before time-out. The time desired is measured in seconds, and entered using a 3 digit number. (060= 1 minute, 180= 3 minutes, etc).

1. Unit must be in Program Mode.
2. Press '8'.
3. Enter call length in seconds (001 to 999).

You will hear two 'beeps' indicating command accepted.

4. If desired, exit Program Mode by pressing '#' (wait for two second tone).
5. To terminate call, press '7'.

### (K) DTMF Echo Test:

1. Press '9'.

The unit will send a tone sequence 1 thru 0 ,\*, #, and then echo any tones received from the caller.

2. To stop test. press '#' (wait for two second tone).
3. To terminate call, press '7'.

### (L) Cycling Relays:

This command causes the HS-2 to leave the programming mode and operate the primary relay timing cycle followed by phone line disconnect.

1. Press '\*'.

---

**OPERATION**

---

**STANDARD MODE**

When the handset is lifted, the HS-2 dials a pre-programmed phone number and monitors the line for the following signals:

**Busy Signal:** *The HS-2 will hang up and redial the number after approximately three busy tones.*

**Ring Signal:** *The HS-2 will hang up and redial the number after approximately six unanswered rings (36 seconds).*

**Voice or Touch-tones:** *This indicates an answer. The unit then enters the Talk Mode.*

**Answering the Call From the HS-2**

Answer the HS-2 incoming call with a short phrase **at least 3 seconds long**. The unit may fail to recognize a short greeting such as "Hello" and may not turn on the microphone.

Once voice communication has been established you may then press keys on your touch-tone telephone to do any of the following:

1. To **Activate** the **Primary Relay** and hang up after time-out, press '0' or '5'.
2. To **Activate** the **Secondary Relay** and hang up after time-out, press '1' or '6'.

**Note:** Activating either power relay will simultaneously activate the alarm shunt relay for the relay activation time plus an additional thirty (30) seconds.

3. To **Terminate** the **Call**, press '7'.
4. To **Reset** the HS-2's **Call Length Timer**, press '8'.

**Note:** The unit will beep twice to warn of auto-call termination in 10 seconds.

5. To **Toggle** on/off the **Secondary Relay**, press '9'. The unit will respond with one beep to indicate that the relay has been deactivated, or two beeps to indicate that the relay has been activated.
6. To **Retrieve** the HS-2's **Site ID** number, press '#'.
7. To **Enter** the **Program Mode**, press '\*' ; followed by the four digit Programming Code.

**Calling the HS-2 To Grant Access**

When a call is placed to the HS-2, the caller can perform any of the above operations with the following exceptions:

1. To **Enter** the **'Talk' Mode**, press '2' or any of the above tones.
2. To **Activate** the **Primary Relay**, press '0' or '5'. You will hear one beep. Enter your four digit Program Code. The relay will activate for the preset cycle duration, and providing 1 beep per second until the end of the cycle.
3. To **Activate** the **Secondary Relay** and hang up after time-out, press '1' or '6'.

**Note:** If the wrong Program code is entered, the unit will immediately hang up. If the program code or other information is not entered completely, the HS-2 will time-out and hang up.

**EMERGENCY MODE**

When the handset is lifted, the HS-2 activates the primary relay for the duration of the call, pulses the secondary and alarm shunt relays for one second, dials a pre-programmed phone number, and monitors the line for the following signals:

**Busy Signal:** *The HS-2 will hang up and redial the number after approximately three (3) busy tones.*

**Ring Signal:** *The HS-2 will hang up and redial the number after approximately six unanswered rings (36 seconds).*

**Voice or Touch-tones:** *This indicates an answer. The unit then enters the Talk Mode.*

**Answering the Call From the HS-2**

Answer the HS-2 incoming call with a short phrase **at least 3 seconds long**. The unit may fail to recognize a short greeting such as "Hello" and may not turn on the microphone.

Once voice communication has been established you may then press keys on your touch-tone telephone to do any of the following:

1. To **Deactivate** the **Secondary and Shunt Relays**, press '0'.
2. To **Activate** the **Secondary and Shunt Relays**, press '5'.
3. To **Terminate** the **Call**, press '7'.
4. To **Reset** the HS-2's **Call Length Timer**, press '8'.

**Note:** The unit will beep twice to warn of auto-call termination in 10 seconds.

5. To **Toggle** on/off the **Primary Relay**, press '9'. The unit will respond with one tone to verify that the relay is deactivated, or two tones to indicate the relay has been activated.
6. To **Retrieve** the HS-2's **Site ID** number, press '\*'.
7. To **Enter** the **Program Mode**, press '#', followed by the four digit Program Code.

When the HS-2 is in the Emergency Mode, the call can only be terminated by the party that answers the call when they press '7' on their telephone keypad.

---

**TROUBLE SHOOTING GUIDE**

---

**NO DIAL TONE**

1. Check input power at unit. Should be 12 VAC.
2. Check that unit is properly grounded to a good Earth ground.
3. Current starved. Increase AC input wire size.
4. Remove power, wait 5 seconds, restore power. Check for dial tone.
5. Check for phone line. Should be 48-52 VDC across phone line terminals (on hook).
6. Check VOLUME adjustment on PC board.
7. Check "SPKR" plug on PC board. Make sure speaker is properly plugged in (Handsfree units).
8. Verify that contacts and wires are clean and tight.

**CANNOT PROGRAM**

1. Incorrect/lost program code.
2. Not entering ' \* ' before program code.
3. Try 'NO DIAL TONE' troubleshooting procedures.
4. Keypad damaged. Check for vandalism.
5. Check that Program Prom/Microprocessor is fully seated.
6. Unit is in the wrong Operational Mode

**LOSES MEMORY**

1. Electrical noise on power line. Install EMI/RFI filter.
2. Excessive electrical noise from strike. Use low current strike.
3. Unit transformer shared with another device (i.e. door strike).

**RESIDENT CANNOT ACTIVATE STRIKE/GATE**

1. Tenant not pressing correct number on phone.
2. Strike/gate operator not wired correctly.
3. Missing or incorrect power to strike or gate operator.
4. Current starved. Increase wire size.
5. Tone may be too brief in duration (cordless phones, etc.).

**AC HUM IN SPEAKER**

1. Phone wires running in same conduit as AC power.
2. Unit not properly grounded.
3. Defective microphone.

**RESIDENT CANNOT HEAR VISITOR**

1. Defective handset/microphone.
2. Person receiving the call answers in too short a duration to activate the HF-2 (person must speak a minimum of 2 seconds to be detected).
3. Excessive background noise.

## CONDENSED GUIDE TO USE and PROGRAMMING

### General

Data between [ ] is a mandatory program key stroke sequence. Data between { } is to be supplied by the programmer. Unit responses are shown between ( ).

### Legend:

d	Dial mode (0= Touch, 1= Rotary)‡	pppp	Program Code
f	Five second relay duration time (1, 2,...9)	r	Ring Count (1, 2, ...9)
iiii	Site ID number (always use four digits)	*	The “star” key of the telephone
lll	Call Length Time in seconds (001, ...999)	#	The “pound sign” key of the telephone
nnn nnnn	Phone Number (up to 12 digits)	☎	Tones returned by the unit

### SECURITY DEPT. OPERATION

When Security personnel receive a call from the unit, they press key [X] on their telephone to:

### STANDARD MODE

- [0,5] Cycle Primary Relay
- [1,6] Cycle Secondary Relay
- [2] Factory Tone Test (answer tone)
- [7] Force disconnect (hang up)
- [8] Extends current Call Timer 3 minutes
- [9] Toggle on/off Secondary Relay (☎ = off, ☎☎ = on)
- [#] Requests Site ID Number
- [\*{pppp}] Enter Program Mode

### EMERGENCY MODE

- [0] Deactivate Secondary (Camera) Relay
- [5] Operate Secondary (Camera) Relay
- [2] Factory Tone Test (answer tone)
- [7] Force disconnect (hang up)
- [8] Extends current Call Timer 3 minutes
- [9] Toggle on/off Primary Relay (☎ = off, ☎☎ = on)
- [\*] Requests Site ID Number
- [#{pppp}] Enter Program Mode

### PROGRAMMING THE UNIT

*Enter the Programming Mode: Call the unit, then press [\*{pppp}] ☎☎*

- [0{f}] ☎☎ Set unit's Gate Open time
- [1{iiii}] ☎☎ Set unit's Site ID number
- [2 then 1-0] ☎ [nnn nnn#] ☎☎ Set unit's Auto dial numbers
- [3{pppp}] ☎☎ Set unit's Program Code
- [5{r}] ☎☎ Set Ring Count before auto answer
- [6{d}] ☎☎ Set Dial Mode‡
  - ‡ Dial Mode
  - 0 = Tone dial only
  - 1 = Rotary dial only
  - 2 = Tone dial with Secondary Relay pulse
  - 3 = Rotary dial with Secondary Relay pulse
- [7{x}] ☎☎ Set Operation Mode, where x = :
  - 0 = Standard mode
  - 1 = Emergency mode
  - 2 = Multiple HF-2's share same phone line
  - 4 = Ring Down mode (Seizes phone line, waits)
- [8{lll}] ☎☎ Set Call Length Time Limit
- [9(tones)#] Echo Test.
- [\*] then 1-0] Verifies primary or backup telephone numbers
- [#] Return to Normal Mode

