

Walk-Behind Concrete Saws

Pro 65® G Model	Pro 65 G 14	Pro 65 G 20	Pro 65 G 26	Pro 65 G 30	Pro 65 G 36	E
Gas Item No.	968980542	968980543	968980544	968980545	968980546	
List Price	\$14752	\$14,852	\$14,965	\$15,399	\$15,761	
Gas w/Water Pump Item No.	968980547	968980548	968980549	968980550	968980551	
List Price	\$14,877	\$14,977	\$15,090	\$15,524	\$15,886	
STANDARD FEATURES						
Blade Guard Capacity - in. (mm)	14 (356)	20 (508)	26 (660)	30 (762)	36 (914)	
Blade Shaft RPM	2,935	2,270	2,270	1,500	1,300	
Max. Depth of Cut - in. (mm)	4-5/8 (117)	7-5/8 (194)	10-1/2 (267)	12 (305)	15 (381)	
Arbor Size	1" (25.4mm) with single drive pin					
Blade Shaft Diameter	1-3/4" (44.5mm)					
Blade Shaft Bearings	Super-duty, triple sealed spherical rolling bearings (Rex)					
Blade Shaft Drive	Matched set of 2-four band 3VX premium belts					
Blade Guard Attachment	Single, vertical slip-on tab					
Blade Control	Electrohydraulic pump raises blade; blade can be raised or lowered with switch off; switch controlled raise/lower on speed control handle (Quick Stick™); console mounted depth stop control limits cutting depth at selected measurement					
Axle Front / Rear	1-1/2" (38.1mm) diameter / 1-1/4" (32mm) diameter					
Wheels Front	8" x 3" x 1" (203 x 76 x 25.4mm) with roller bearing					
Rear	10" x 3" x 1-1/4" (254 x 76 x 35mm) keyed					
Handle Bars	Two-position					
Transmission	Eaton model 10; chain and gear reduction system with console mounted engage/disengage lever; Quick Stick™ one hand drive and blade depth control; engaged transmission provides for dynamic braking					
Control Speed	Single linear control on console; forward, reverse, dynamic breaking, neutral stop Infinite speeds; 0 to 200 FPM					
Chassis	Super reinforced; console welded onto frame for rigidity; extra shaft support brake welded on lift cylinder					
Weight - lb. (kg)	Crated	1,393 (633)	1,395 (634)	1,386 (630)	1,407 (640)	1,430 (650)
	Uncrated	1,306 (594)	1,322 (601)	1,343 (610)	1,364 (620)	1,387 (630)
POWER SOURCE						
Engine/Motor	Wisconsin Gas					
Specifications	V465					
Max. Horsepower	65					
Displacement (cu. in.)	177					
Bore / Stroke - in. (mm)	3.75 (95.3) / 4 (101.6)					
Cylinders/Stroke	4/4					
Fuel Capacity - gal. (l)	9 (37)					
Oil Capacity - pt. (l)	7 (6.7)					
Air Filter	Dual element radial seal w/ turbo style pre-cleaner					
Starter	Electric					
Engine Coolant	Air					

SAW DIMENSIONS

Crated Dimensions: L64" x W42" x H56-1/2" (1626 x 1067 x 1435mm)

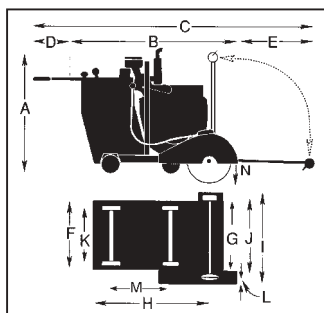

A: Height (w/Muffler)

B: Min. Saw Length, Pointer Up and Handles In

C: Max. Saw Length, Pointer Down and Handles Out

D: Handle Extension

E: Max. Pointer Extension

F: Frame Width

G: Inner Flange to Inner Flange Width

H: Frame Length

I: Saw Width

J: Front - Outside to Outside Wheel Width

K: Rear - Outside to Outside Wheel Width

L: Blade to Wall

M: Wheel Base Length

N: Blade Shaft Max. Ht.

INCHES

METRIC (mm)

70

1,778

54

1,372

108

2,743

30

762

38

965

25

635

29-7/8

759

50

1,270

32-1/2

826

22-1/2

572

22-1/2

572

2-7/8

73

21-1/4

540