

LIMITATIONS OF LIABILITY	4
CHAPTER 1. GETTING STARTED	5
1.1 Introduction.....	5
1.2 System Descriptions.....	5
1.3 System Applications	5
1.4 System Specifications	6
1.5 System Accessories	6
1.6 Unpacking the System.....	7
1.7 Warranty	7
CHAPTER 2. INSTALLATION	8
CHAPTER 3. LOCAL PROGRAMMING	11
3.1 * Key	12
3.2 # Key	12
3.3 * and # Keys (Reset Master Code to factory default).....	12
3.4 0 Key	12
3.5 Function Code 00 Change Unit Master Code	12
3.6 Function Code 01 Individual Access Code	13
3.6.1 Add Individual Access Code.....	13
3.6.2 Delete Individual Access Code.....	13
3.6.3 Overwrite existing Access Code.....	13
3.7 Function Code 60 Delete Individual Access Code Index Number 01-10	13
3.8 Function Code 61 Delete Individual Access Code Index Number 11-20	14
3.9 Function Code 62 Delete Individual Access Code Index Number 21-30	14
3.10 Function Code 63 Delete Individual Access Code Index Number 31-40	14
3.11 Function Code 64 Delete Individual Access Code Index Number 41-50	14
3.12 Function Code 65 Delete All Individual Access Codes Index Number 01-50.....	15
3.13 Function Code 70 Non-Indexed Call Forwarding	15
3.13.1 Enable Non-Indexed Call Forwarding.....	15
3.13.2 Disable Non-Indexed Call Forwarding.....	15
3.14 Function Code 71-75 Add or Delete Indexed Call Forwarding.....	15
3.14.1 Add Indexed Call Forwarding	16
3.14.2 Delete Indexed Call Forwarding	16
3.14.3 Rewrite Existing Indexed Call Forwarding	16
3.15 Function Code 76 Delete All Call Forwarding Phone Number	16
3.16 Function Code 87 Enable or Disable Automatic Call Forwarding	17
3.17 Function Code 88 Select Automatic Call Forwarding Index Number	17
3.18 Function Code 89 Set Automatic Call Forwarding Time	17
3.19 Function Code 90 Manual Unlock or Lock	17
3.20 Function Code 91 Talk-Time.....	18
3.21 Function Code 92 Door Open Interval.....	18
3.22 Function Code 93 Lock -out Count	18
3.23 Function Code 94 Auxiliary Mode	19
3.24 Function Code 95 Alarm Mode.....	19
3.25 Function Code 96 System Answer Mode	19
3.26 Function Code 97 Do not Disturb Mode	20
3.27 Function Code 98 Select Initiating Premise Call Key # or *	20
3.28 Function Code 99 Set Memory to Factory Default	20
CHAPTER 4. REMOTE PROGRAMMING FROM PREMISE LOCATION	21
4.1 Add Individual Access Code Index Number 01-50.....	21
4.2 Delete Individual Access Code (Function Code 60-64)	21
4.3 Delete All Access Codes (Function Code 65).....	22
4.4 Non-Indexed Call Forwarding (Function Code 70).....	22
4.4.1 Add Non-Indexed Call Forwarding.....	22
4.4.2 Delete Non-Indexed Call Forwarding.....	22
4.5 Indexed Call Forwarding (Function Code 71-75)	22
4.5.1 Add Indexed Call Forwarding	22

4.5.2	Delete Existing Indexed Call Forwarding.....	22
4.5.3	Rewrite Existing Indexed Call Forwarding.....	23
4.6	Delete All Call Forwarding Phone Number (Function Code 76).....	23
4.7	Enable or Disable Automatic Call Forwarding (Function Code 87).....	23
4.8	Selecting Automatic Call Forwarding Index Number (Function Code 88).....	23
4.9	Set Automatic Call Forwarding Time (Function Code 89).....	24
4.10	Unlock or Lock Door or Gate (Function Code 90).....	24
4.11	Talk Time (Function Code 91).....	24
4.12	Door Open Interval (Function Code 92).....	24
4.13	Lock-out Count (Function Code 93).....	25
4.14	Auxiliary Mode (Function Code 94).....	25
4.15	Alarm Mode (Function Code 95).....	25
4.16	System Answer Mode (Function Code 96).....	25
4.17	Do not Disturb Mode (Function Code 97).....	25
4.18	Select Initiating Premise Call Key # or * (Function Code 98).....	26
4.19	Set Memory to Factory Default.....	26

CHAPTER 5. REMOTE PROGRAMMING FROM REMOTE LOCATION 27

5.1	Add Individual Access Code (Index Number 01-50).....	27
5.2	Delete Individual Access Code (Function Code 60-64).....	27
5.3	Delete All Access Codes (Function Code 65).....	27
5.4	Non-Indexed Call Forwarding (Function Code 70).....	28
5.4.1	Add Non-Indexed Call Forwarding.....	28
5.4.2	Delete Non-Indexed Call Forwarding.....	28
5.5	Indexed Call Forwarding (Function Code 71-75).....	28
5.5.1	Add Indexed Call Forwarding.....	28
5.5.2	Delete Existing Indexed Call Forwarding.....	29
5.5.3	Rewrite Existing Indexed Call Forwarding.....	29
5.6	Delete All Call Forwarding Phone Number (Function Code 76).....	30
5.7	Enable or Disable Automatic Call Forwarding (Function Code 87).....	30
5.8	Selecting Automatic Call Forwarding Index Number (Function Code 88).....	30
5.9	Set Automatic Call Forwarding Time (Function Code 89).....	31
5.10	Unlock or Lock Door or Gate (Function Code 90).....	31
5.11	Talk Time (Function Code 91).....	31
5.12	Door Open Interval (Function Code 92).....	31
5.13	Lock-out Count (Function Code 93).....	32
5.14	Auxiliary Mode (Function Code 94).....	32
5.15	Alarm Mode (Function Code 95).....	32
5.16	System Answer Mode (Function Code 96).....	33
5.17	Do not Disturb Mode (Function Code 97).....	33
5.18	Select Initiating Premise Call Key # or * (Function Code 98).....	33
5.19	Set Memory to Factory Default.....	33

CHAPTER 6. SYSTEM'S OPERATIONS..... 34

6.1	How to Initiate Call from the AeGIS 4000.....	34
6.2	How to Answer the AeGIS 4000 Call and Extend the Talk Time.....	34
6.3	How to Provide Access to Visitor.....	34
6.4	How to Use Call Waiting Feature.....	34
6.5	How to Use Personal Access Code.....	35
6.6	How to Enable and Disable Call Forwarding.....	35
6.6.1	Enable Indexed Call Forwarding via System's Keypad.....	35
6.6.2	Enable Indexed Call Forwarding via Premise Phone.....	35
6.6.3	Enable Indexed Call Forwarding from Remote Location.....	36
6.7	How to Activate Automatic Call Forwarding.....	36
6.8	How to Unlock Cycle, Unlock Hold and Lock.....	36
6.8.1	Via the System's Keypad.....	36
6.8.2	From Premise Phone.....	37
6.8.3	From Remote Location.....	37
6.9	How to Hang Up AeGIS Calls from Premise or Remote Location.....	37
6.10	How to Call and Talk to the AeGIS from Premise or Remote Location.....	37
6.10.1	From Premise Location.....	37
6.10.2	From Remote Location.....	37

6.11 How to Use Alarm Notification	37
6.12 How to use Auxiliary Input Pin (AUI).....	38
6.13 How to use Do not Disturb.....	38
6.14 How to Use Speed Dialing.....	38

CHAPTER 7. TROUBLE SHOOTING GUIDES..... 39

CHAPTER 8. PARAMETERS WORKSHEET..... 42

□

Limitations of Liability

This manual is subject to change without notice.

Pach and Company is not liable for any errors that might occur from use of this document, nor is any commitment to update the information herein implied.

Pach and Company does not assume any liability for any damages, which may arise in installation or use of the AeGIS 4000 Series. Pach and Company does not assume liability for any incompatibility between the AeGIS 4000 Series and users devices.

Pach & Company reserves the right to make changes without prior notice to any products in order to improve reliability, function or design.

Chapter 1. Getting Started

1.1 Introduction

Pach & Company thanks and congratulates you on the purchase of your AeGIS 4000 Series Telephone Access Control System.

This manual is designed to guide you through the proper programming and use of the AeGIS 4000 Series. It is important for you to read and follow the manual completely.

The Aegis 4000 Series comes with two years warranty, but we are so confident in our product and our dealer's ability to install them properly, we will include lightning strikes in our two years warranty if surge protection is installed with the system.

1.2 System Descriptions

The AeGIS 4000 Series utilizes microprocessor technology to provide security as well as convenience to you. It is designed for residential applications or any location where access control is required. It utilizes **"no phone bill"** technology, where a dedicated telephone line is not necessary. Authorization for access control is through the telephone line, or with the tenant's own access code, which is entered on the system keypad. The premise **MUST** have a telephone device (telephone set) to allow remote visitor access.

Also, as a standard feature, a tenant is allowed to forward calls automatically or manually, "call" the Aegis unit and converse with the visitor and "remote programming" using a touch-tone phone.

The system parameters and tenants database can be entered locally via the unit's keypad or remotely via a touch-tone phone. EEPROM technology is used for the AeGIS 4000 series. Tenants database will not be lost during a power failure.

1.3 System Applications

The AeGIS 4000 Series can be installed for various types of applications to suit your needs. The block diagrams below are examples of typical applications. If you need more information about your applications, you may call us at 1 (888) 678-7224 from 7:30 AM – 4:30 PM Pacific Standard Time.

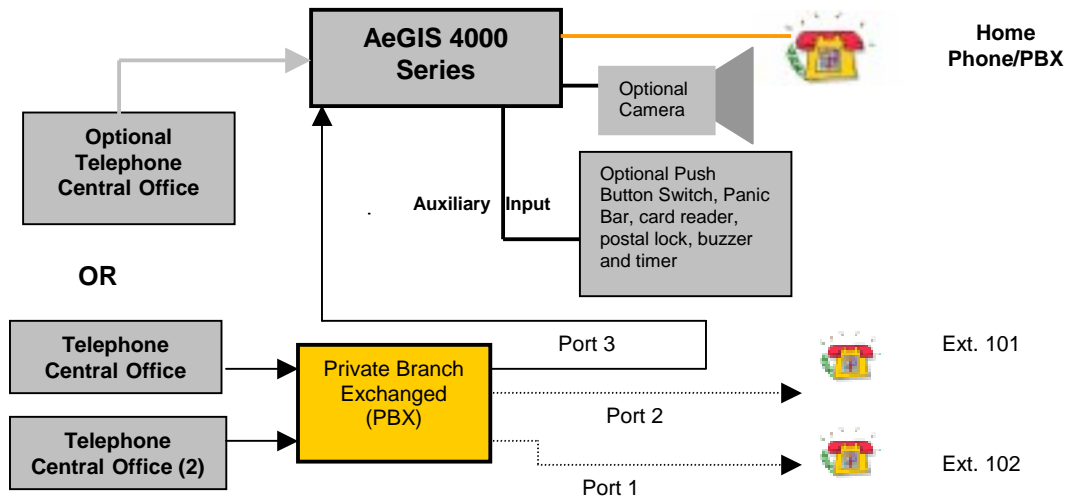

1.4 System Specifications

Standard features:

- No Phone Bill Technology.
- Program and store personal access codes.
- Unlock door or gate locally or remotely by tenant.
- Unlock door or gate by the tenant using private access code.
- Built-in Auxiliary input
- Remote Phone Programming.
- Works behind a PBX to dial an extension (analog only).
- Programmable features:
 - Lock-out Count
 - Manual Unlock and Lock
 - 4 Digit Unit master Code
 - Open Interval
 - Talk Time
 - Personal Access Code
 - Call Forwarding automatic or manual

Technical Specifications:

Power Input: 12VAC 20VA UL Listed Transformer (Pach supplied) or 13.5 VDC 20VA

Current Consumption: 95mA idle, 300mA operation

Emergency Battery: 13.5VDC, 4Ahr rechargeable (not supplied)

Telephone Line: Standard voice grade RJ11 jack

Operating Environment: Temp. 0°F to +140°F Relative Humidity 0% to 95% non-condensing

Relay Output: Form C Dry Contact 120 VAC 10A/24VDC 10A/250VAC 7A

Memory Type: EEPROM

Tone Detection: Crystal controlled, capable of detecting short bursts 80 ms

Mounting: Surface or Semi-Flush Mount

Construction: 16 Gauge Stainless Steel

Shipping: 8 lbs. or 3.6 kg. approximate

Dimensions: 9.0" (22.9Cm) x 6.7" (17Cm) x 3.25" (8.3Cm) (HWD)

NOTE: Specifications are subject to change without notice.
The AeGIS 4000 Series can be installed on a PBX analog port to dial an extension, but it can't call an outside phone number from a PBX line.

1.5 System Accessories

Pach and Company Part Number	Description
NLK4	Night-light kit.
SFM4	Semi-flush Mounting Ring
SFM4N	Semi-flush Mounting Ring with Night-light kit
SF47-6	Wide Semi-Flush Mounting Ring
SFM4N-6	Wide Semi-Flush Mounting Ring with Night-light kit

4SHLD	Sun Shield
ASP1	AC and Telephone Surge Protector
AHP-5	Heater pad with Thermostat
APM1	AeGIS Pedestal Mounting Post
4XMFR	4000 Series Power Transformer
AVP4	AeGIS Video Package
AVP4C	AeGIS Video Package (Color)
AVPX	AeGIS Video Package Power Transformer
AKYS	AeGIS key Sets (2 keys per set)
4MAN	AeGIS 4000 Series Installation and program manual
Bronze Chrome Finish Option	Contact factory

1.6 Unpacking the System

Check the serial number on the printed circuit board, cabinet and warranty card, they must match. If they do not match, please contact Pach and Company toll free number at **(888) 678-7224**. All the items listed below come with the AeGIS 4000 Series.

- AeGIS 4000 Series System.
- 4XMFR (4000 Power Transformer, 12VAC 20VA).
- 5-pin terminal connector (inside the unit's cabinet).
- 6-pin terminal connector (inside the unit's cabinet).
- Key set (2 keys per set)
- Interceptor Module.
- Owners Manual.
- Warranty Card with unit's serial number.

If you have missing items, please contact Pach and Company at **(888) 678-7224**.

1.7 Warranty

The AeGIS 4000 Series come with **two (2) years warranty parts and labor**. We will include lightning strikes in our two years warranty if surge protection is installed with the systems. The above warranties are subject to the following conditions.

- The serial number on the printed circuit board must match the serial number on the cabinet.
- The system's failure is not caused by vandalism, improper installation, misuse or abuse.
- Physically damaged product is not acceptable for repair or exchange within or after warranty.
- The warranty will be void and null if the product has been repaired or modified by unauthorized party without authorization from the Pach and Company Technical Department.
- If for some reason your system cannot be repaired, Pach and Company will replace it with an identical product of equal value.
- You must obtain a Return Merchandise Authorization (RMA) number from Pach and Company Technical Department before you can send back the product to factory for repair.
- You are responsible for all transportation and insurance charges for the products shipped to the Pach and Company repair center.

Chapter 2. Installation

A proper installation of the AeGIS system is very essential. You MUST follow the installation-wiring steps as shown in figure 2.1.

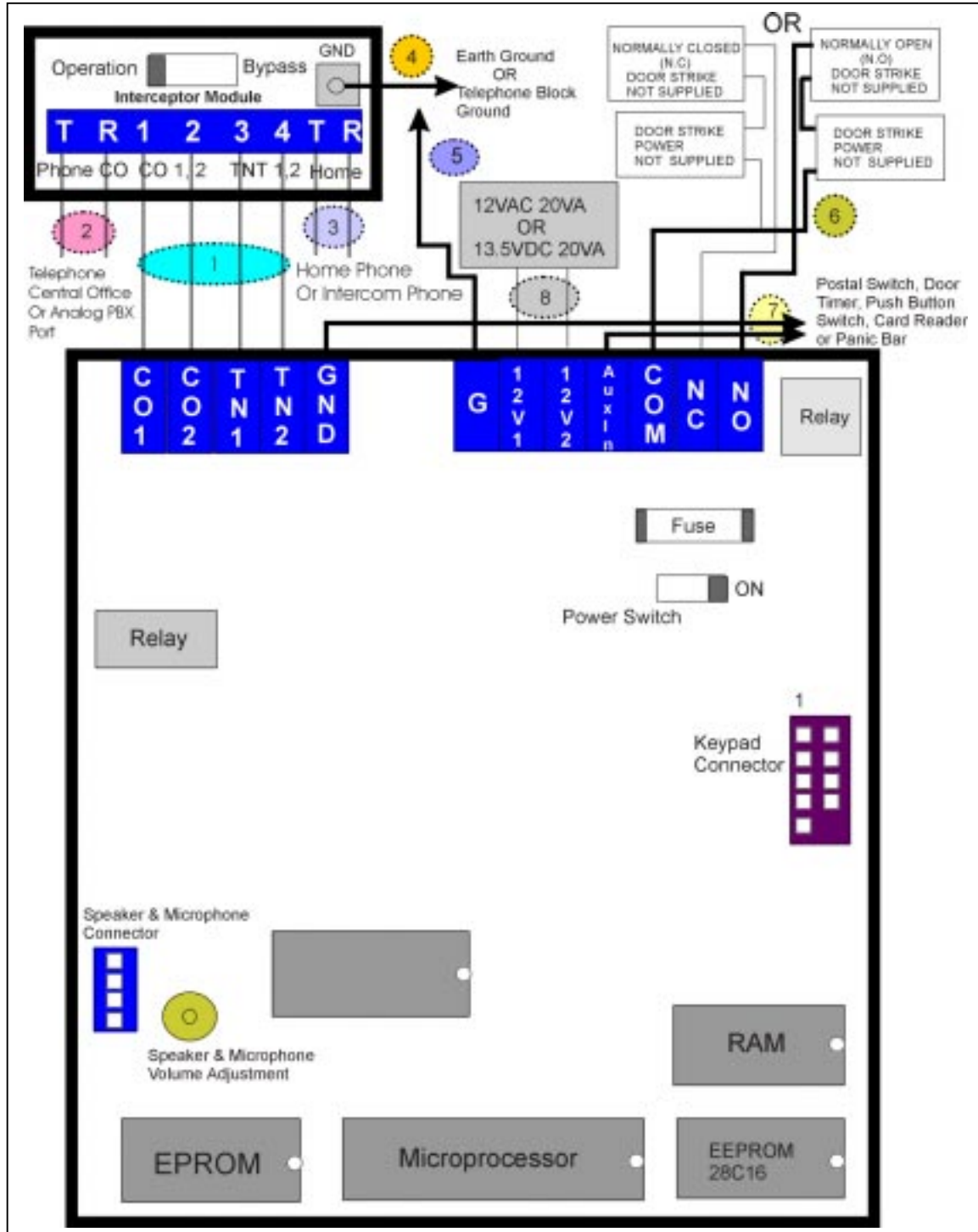

The wiring diagram in figure 2.1 is numbered. Follow the step below according to the wiring number shown in figure 2.1.

Step 1 CO1, CO2, TN1, and TN2 to 1, 2, 3 and 4.

The Interceptor Module can be installed inside or outside the AeGIS 4000 cabinet.

- The maximum distance between the AeGIS 4000 and the Interceptor Module and the Home Phone cannot be exceeded 2200 feet using 18 -gauge 4-conductors shielded stranded wires. **Warning:** Longer distance is not recommended.
- Ground one end of the shield into the earth ground or telephone ground block.
- If the Interceptor Module is inside the AeGIS 4000 cabinet, 22-gauge 4-conductors stranded wires can be used,

Step 2 PHONE CO (Central Office).

Connect to Telephone Central Office or Analog Private Branch Exchanged (PBX). **If the AeGIS 4000 is only used as an Intercom System, skip this step and proceed to Step 3.**

- 18-gauge 2-conductors shielded stranded wires are recommended, to avoid static and radio station transmission.
- Ground one end of the shield into the earth ground or telephone ground block.

Step 3 HOME PHONE

Connect to a Home Phone Set.

- A maximum distance between the AeGIS 4000, Interceptor Module and the Home Phone cannot be exceeded 2200 feet using 18 -gauge 4-conductors shielded stranded wires. **Warning:** Longer distance with bigger gauge wires is not recommended. Do not Phone Central Office to Home Phone Terminal.

NOTE: If you install the AeGIS 4000 on dedicated phone for call forwarding only, do not do this step, return to Step 2.

Step 4 INTERCEPTOR MODULE GND

Connect to Telephone Ground Block or Earth Ground using 16-gauge stranded wire.

Step 5 G.

Connect to Telephone Ground Block or Earth Ground using 16-gauge stranded wire.

Step 6 DOOR STRIKE.

Form C Dry Contact (120 VAC 10A/ 24 VDC 10A/ 250 VAC 7A) Normally Open (N.O) and Normally Closed (N.C).

Connect to Normally Open (N.O) and COM if normally open door strike is used. Door is closed if the strike is not energized and open if energized.

Connect to Normally Closed (N.C) and COM if normally closed door strike is used. Door is closed if the strike is energized and open if not energized

- 18-gauge 2-conductors stranded is recommended.

Step 7 AUXIN.

Connect Push Button Switch, Panic Bar, Card Reader, Buzzer, and Postal Lock using minimum 22-gauge wires.

Step 8 POWER.

ONLY use a Class 2 transformer rated 12 VAC 20VA (supplied) or 13.5 VDC 20 VA to power the AeGIS 4000. Optional 12 VDC 4Ahr battery back up with built-in charger can be installed as shown in figure 2.2.

Warning: Do not use 12 VAC 20VA (supplied), if battery back up is used, to do so may damage the system or cause injury.

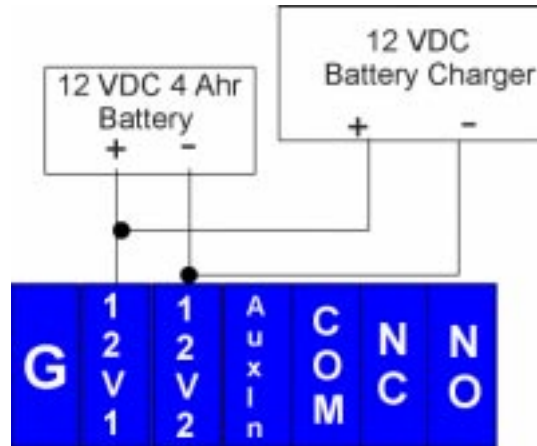

Figure 2.2

Chapter 3. Local Programming

This chapter explains how to program the AeGIS 4000 Series. It provides a listing of Function Codes, descriptions and reference page numbers. Factory default settings are listed in this chapter. The default settings remain in effect until they are changed via the parameter programming.

Reference Keys	Description	Reference Page
*	Exit Programming Mode or hang-up.	12
#	To accept program	12
* and #	To reset the master code to factory default (0000), see instruction.	12
0	To delete or to hold call and switch in call waiting, see instruction.	12

Function Codes	Description	Reference Page
00	Change Unit Master Code	12
01-50	Individual Access Code Index Number 01-50	13
60	Delete Individual Access Code Index Number 1-10	13
61	Delete Individual Access Code Index Number 11-20	14
62	Delete Individual Access Code Index Number 21-30	14
63	Delete Individual Access Code Index Number 31-40	14
64	Delete Individual Access Code Index Number 41-50	14
65	Delete All Individual Access Codes on index Number 01-50	15
70	Non-indexed Call Forwarding	15
71	Add or Delete Indexed Call Forwarding Phone # 1	15
72	Add or Delete Indexed Call Forwarding Phone # 2	15
73	Add or Delete Indexed Call Forwarding Phone # 3	15
74	Add or Delete Indexed Call Forwarding Phone # 4	15
75	Add or Delete Indexed Call Forwarding Phone # 5	15
76	Delete All Call Forwarding Phone Number	16
87	Enable or Disable Automatic Call Forwarding	17
88	Select Automatic Call Forwarding Index Number	17
89	Set Automatic Call Forwarding Time	17
90	Manual Unlock or Lock	17
91	Talk-time	18
92	Door Open Interval	18
93	Lock-out count	18
94	Auxiliary Mode	19
95	Alarm Mode	19
96	System Answer Mode	19
97	Do not Disturb Mode	20
98	Select Initiating Premise Call Key (# or *)	20
99	Set the memory to factory default	20

Parameter default Settings Tables

Function Code	Parameter	Default Setting
00	Unit Master Code	0000
91	Talk-time	60 seconds
92	Door open interval	12 seconds
93	Lock-out count	3 tries
94	Auxiliary	Disabled
95	Alarm mode (local and remote)	Local: 10 seconds Remote: 60 seconds
Event	Factory Setting (non programmable)	
Visitor call (local)	30 seconds rings	
Alarm beep (speaker)	30 seconds	

Alarm call (local)	10 seconds
Alarm call (remote)	60 seconds
Unit block-out time	60 seconds
Call waiting beeps	3 times

NOTE: If you are in programming mode and you leave the system idle for 30 seconds, the programming mode will be aborted and you will hear **“Three Short Beeps”**.

3.1 * Key

Is used only in local programming to exit the programming mode or hang-up the call.

3.2 # Key

Is used to accept program.

3.3 * and # Keys (Reset Master Code to factory default)

A combination of * # keys and the system's power reset are used to reset the system master code to factory default (0000). You must have the key to the system. Follow the steps below to set the system master code to factory default.

- Step 1** Open the panel and turn the power switch to OFF, see figure 2.1.
- Step 2** Press and hold * and # key simultaneously and turn the system's power “On” (switch to the left). You will hear **“Two Short Beeps”** then **“Three Short Beeps”** then release the * and #. Your master code is now 0000.

3.4 0 key

Is used to delete the existing program such call forwarding phone number or access code. It is also used to hold call and switch call.

3.5 Function Code 00 – Change Unit master Code

The default system Master Code (0000) must be changed for security purposes. The Master Code is always 4-digit long.

- Step 1** Press 0 and # simultaneously then release. If you are in the programming mode, proceed to step 2.
- Step 2** Enter the 4-digit Master Code (factory default is 0000) and you will hear **“One Short Beep”**. If you entered an invalid master code you will hear **“One Long Beep”**, repeat step 1. Should your master code become lost or forgotten see section 3.3 Reset Master Code.
- Step 3** Enter 00 then #, you will hear **“No Beep”**.
- Step 4** Enter new 4-digit Master Code then press # then you will hear **“One Short Beep”** and proceed to step 5 or if you decided not to change the existing Master Code press * to exit and you will hear **“Three Short Beeps”**
- Step 5** Continue to program another parameter or press * to exit; you will hear **“Three Short Beeps”**.

3.6 Function Code 01- 50 – Individual Access Code

Is used to add individual access code, overwrite or delete the existing access code. You may have a maximum of 4-digit fifty (50) programmable access codes. Each access code is stored in function code (01-50). The Function Code

01-50 may also be called **Index Number** (01-50). The Index number 01-50 is the location where the access code (s) is stored.

3.6.1 Add individual access code

- Step 1** Press 0 and # simultaneously then release. If you are in the programming mode, proceed to step 2.
- Step 2** Enter the 4-digit Master Code (factory default is 0000) and you will hear **“One Short Beep”**. If you entered an invalid master code you will hear **“One Long Beep”**, repeat step 1. Should your master code become lost or forgotten see section 3.3 Reset Master Code.
- Step 3** Enter the Index Number (01 – 50) then #, you will hear **“No Beep”**. If the associated Index Number has an access code programmed, you will hear **“Two Long Beeps”**. Press *, you will hear **“One Short Beep”** and select another Index Number.

NOTE: The access code does not have to be stored in sequence. You may choose Index 50 to program the first access code.

- Step 4** Enter the 4-digit access code then #, you will hear **“One Beep”**.
- Step 5** Return to step 3 to program another access code or enter another Function Code to program another parameter, otherwise press * to exit and you will hear **“Three Short Beeps”**.

3.6.2 Delete individual access code

- Step 1** Press 0 and # simultaneously then release. If you are in the programming mode, proceed to step 2.
- Step 2** Enter the 4-digit Master Code (factory default is 0000) and you will hear **“One Short Beep”**. If you entered an invalid master code you will hear **“One Long Beep”**, repeat step 1. Should your master code become lost or forgotten see section 3.3 Reset Master Code.
- Step 3** Enter the Index Number (01 – 50) where you stored the access code to be deleted.
- **“Two Long Beeps”** if the Index Number has an associated access code, proceed to step 4.
 - **“No Beep”** if the Index Number has no associated access code and press “*” and repeat this step.
- Step 4** Enter 0 then # to delete the access code, you will hear **“One Short Beep”**.
- Step 5** Return to step 3 to delete another access code or enter another Function Code to program another parameter, otherwise press * to exit and you will hear **“Three Short Beeps”**.

3.6.3 Overwrite existing access code

- Step 1** Press 0 and # simultaneously then release. If you are in the programming mode, proceed to step 2.
- Step 2** Enter the 4-digit Master Code (factory default is 0000) and you will hear **“One Short Beep”**. If you entered an invalid master code you will hear **“One Long Beep”**, repeat step 1. Should your master code become lost or forgotten see section 3.3 Reset Master Code.
- Step 3** Enter the Index Number where you stored the access code you want to overwrite, and you will hear **“Two Long Beeps”** (the index number has an associated access code).
- Step 4** Enter 1 then #, you will hear **“No Beep”** and enter the new access code and you will hear **“One Short Beep”**.
- Step 5** Return to step 3 to overwrite another access code or enter another Function Code to program another parameter, otherwise press * to exit and you will hear **“Three Short Beeps”**.

3.7 Function Code 60 Delete Individual Access Code Index Number 01-10

Is used to delete individual access codes index number 01-10. This function code will allow you to delete ten-Index Number at once.

- Step 1** Press 0 and # simultaneously then release. If you are in the programming mode, proceed to step 2.
- Step 2** Enter the 4-digit Master Code (factory default is 0000) and you will hear **“One Short Beep”**. If you entered an invalid master code you will hear **“One Long Beep”**, repeat step 1. Should your master code become lost or forgotten see section 3.3 Reset Master Code.
- Step 3** Enter 60 then #, you will hear **“One Short Beep”**.

Step 4 Enter another Function Code to program another parameter; otherwise press * to exit and you will hear **“Three Short Beeps”**.

3.8 Function Code 61 Delete Individual Access Code Index Number 11-20

Is used to delete individual access codes index number 11-20. This function code will allow you to delete ten-Index Number at once.

Step 1 Press 0 and # simultaneously then release. If you are in the programming mode, proceed to step 2.

Step 2 Enter the 4-digit Master Code (factory default is 0000) and you will hear **“One Short Beep”**. If you entered an invalid master code you will hear **“One Long Beep”**, repeat step 1. Should your master code become lost or forgotten see section 3.3 Reset Master Code.

Step 3 Enter 61 then #, you will hear **“One Short Beep”**.

Step 4 Enter another Function Code to program another parameter; otherwise press * to exit and you will hear **“Three Short Beeps”**.

3.9 Function Code 62 Delete Individual Access Code Index Number 21-30

Is used to delete individual access codes index number 21-30. This function code will allow you to delete ten-Index Number at once.

Step 1 Press 0 and # simultaneously then release. If you are in the programming mode, proceed to step 2.

Step 2 Enter the 4-digit Master Code (factory default is 0000) and you will hear **“One Short Beep”**. If you entered an invalid master code you will hear **“One Long Beep”**, repeat step 1. Should your master code become lost or forgotten see section 3.3 Reset Master Code.

Step 3 Enter 62 then #, you will hear **“One Short Beep”**.

Step 4 Enter another Function Code to program another parameter; otherwise press * to exit and you will hear **“Three Short Beep”**.

3.10 Function Code 63 Delete Individual Access Code Index Number 31-40

Is used to delete individual access codes index number 31-40. This function code will allow you to delete ten-Index Number at once.

Step 1 Press 0 and # simultaneously then release. If you are in the programming mode, proceed to step 2.

Step 2 Enter the 4-digit Master Code (factory default is 0000) and you will hear **“One Short Beep”**. If you entered an invalid master code you will hear **“One Long Beep”**, repeat step 1. Should your master code become lost or forgotten see section 3.3 Reset Master Code.

Step 3 Enter 63 then #, you will hear **“One Short Beep”**.

Step 4 Enter another Function Code to program another parameter; otherwise press * to exit and you will hear **“Three Short Beeps”**.

3.11 Function Code 64 Delete Individual Access Code Index Number 41- 50

Is used to delete individual access codes index number 41-50. This function code will allow you to delete ten-Index Number at once.

Step 1 Press 0 and # simultaneously then release. If you are in the programming mode, proceed to step 2.

Step 2 Enter the 4-digit Master Code (factory default is 0000) and you will hear **“One Short Beep”**. If you entered an invalid master code you will hear **“One Long Beep”**, repeat step 1. Should your master code become lost or forgotten see section 3.3 Reset Master Code.

Step 3 Enter 64 then #, you will hear **“One Short Beep”**

Step 4 Enter another Function Code to program another parameter; otherwise press * to exit and you will hear **“Three Short Beeps”**.

3.12 Function Code 65 Delete All Individual Access Codes Index Number 01-50

Is used to delete individual access codes index number 01-50. This function code will allow you to delete fifty-Index Number at once.

- Step 1** Press 0 and # simultaneously then release. If you are in the programming mode, proceed to step 2.
- Step 2** Enter the 4-digit Master Code (factory default is 0000) and you will hear **“One Short Beep”**. If you entered an invalid master code you will hear **“One Long Beep”**, repeat step 1. Should your master code become lost or forgotten see section 3.3 Reset Master Code.
- Step 3** Enter 65 then #, you will hear **“One Short Beep”**.
- Step 4** Enter another Function Code to program another parameter; otherwise press * to exit and you will hear **“Three Short Beeps”**.

3.13 Function Code 70 Non-Indexed Call Forwarding

If the phone number of the non-indexed call forwarding is programmed, the “Intercom Mode” will be disabled. The AeGIS 4000 will call the phone number programmed in Function Code 70.

3.13.1 Enable Non-Indexed Call Forwarding

- Step 1** Press 0 and # simultaneously then release. If you are in the programming mode, proceed to step 2.
- Step 2** Enter the 4-digit Master Code (factory default is 0000) and you will hear **“One Short Beep”**. If you entered an invalid master code you will hear **“One Long Beep”**, repeat step 1. Should your master code become lost or forgotten see section 3.3 Reset Master Code.
- Step 3** Enter 70 then #, you will hear **“No Beep”**.
- Step 4** Enter the phone number you want to forward the call up to 11-digit then press #, you will hear **“One Short Beep”**.
- Step 5** Enter another Function Code to program another parameter; otherwise press * to exit and you will hear **“Three Short Beeps”**.

3.13.2 Disable Non-Indexed Call Forwarding

Disabling the Non-Indexed Call Forwarding will delete the telephone number programmed on Function Code 70 Non-Indexed Call Forwarding and the AeGIS 4000 will be reset to intercom mode.

- Step 1** Press 0 and * simultaneously then release.
- Step 2** Press 70 then # to delete the delete non-indexed telephone number, you will hear **“Three Short Beeps”**. Now, the AeGIS 4000 is reset to **“Intercom Mode”**.

3.14 Function Code 71-75 Add or Delete Indexed Call Forwarding

You may program up to 5 Indexed Call Forwarding phone number but you only can enable one at a time. The indexed call forwarding is used to forward the call **automatically** or **manually** from the AeGIS 4000.

The Function Code 71-75 may also be called Index 71-75. **See Chapter 4 System’s Operation to enable call forwarding.** **NOTE:** Automatic call forwarding will be enabled after phone number is programmed in index 71.

3.14.1 Add Indexed Call Forwarding

- Step 1** Press 0 and # simultaneously then release. If you are in the programming mode, proceed to step 2.
- Step 2** Enter the 4-digit Master Code (factory default is 0000) and you will hear **“One Short Beep”**. If you entered an invalid master code you will hear **“One Long Beep”**, repeat step 1. Should your master code become lost or forgotten see section 3.3 Reset Master Code.

- Step 3** Enter Index Number (71 – 75) then #, you will hear **“No Beep”**. If you hear **“Two Long Beeps”**, the Index Number has an associated phone number programmed. Press *, you will hear **“One Short Beep”** and select another Index Number (71 – 75).

NOTE: You do not need to store the Call forwarding telephone number in sequence Index Number. You may use Index Number 71-75.

- Step 4** Enter the call forwarding phone number up to 11-digit then press #, you will hear **“One Short Beep”**.

- Step 5** Enter another Index Number or Function Code to program another Call Forwarding or parameter otherwise press * to exit and you will hear **“Three Short Beeps”**.

3.14.2 Delete Indexed Call Forwarding

- Step 1** Press 0 and # simultaneously then release. If you are in the programming mode, proceed to step 2.
- Step 2** Enter the 4-digit Master Code (factory default is 0000) and you will hear **“One Short Beep”**. If you entered an invalid master code you will hear **“One Long Beep”**, repeat step 1. Should your master code become lost or forgotten see section 3.3 Reset Master Code.
- Step 3** Enter Index Number (71 – 75) then #, you will hear **“Two Long Beeps”**. If you hear **“No Beep”**, the Index Number does not have an associated call forwarding phone number programmed. Press *, you will hear **“One Short Beep”** and select another Index Number (71 – 75).
- Step 4** Enter 0 then #, you will hear **“One Short Beep”**.
- Step 5** Enter another Index Number or Function Code to delete another Call Forwarding or to program another parameter otherwise press * to exit and you will hear **“Three Short Beeps”**.

3.14.3 Rewrite Existing Indexed Call Forwarding

- Step 1** Press 0 and # simultaneously then release. If you are in the programming mode, proceed to step 2.
- Step 2** Enter the 4-digit Master Code (factory default is 0000) and you will hear **“One Short Beep”**. If you entered an invalid master code you will hear **“One Long Beep”**, repeat step 1. Should your master code become lost or forgotten see section 3.3 Reset Master Code.
- Step 3** Enter Index Number (71 – 75) then #, you will hear **“Two Long Beeps”**. If you hear **“No Beep”**, the Index Number does not have an associated call forwarding number programmed. Press *, you will hear **“One Short Beep”** and select another Index Number (71 – 75).
- Step 4** Enter 1 then #, you will hear **“No Beep”** and enter a new call forwarding phone number up to 11-digit, you will hear **“One Short Beep”**.
- Step 5** Enter another Index Number or Function Code to delete another Call Forwarding or to program another parameter otherwise press * to exit and you will hear **“Three Short Beeps”**.

3.15 Function Code 76 Delete All Call Forwarding Phone Number

- Step 1** Press 0 and # simultaneously then release. If you are in the programming mode, proceed to step 2.
- Step 2** Enter the 4-digit Master Code (factory default is 0000) and you will hear **“One Short Beep”**. If you entered an invalid master code you will hear **“One Long Beep”**, repeat step 1. Should your master code become lost or forgotten see section 3.3 Reset Master Code.
- Step 3** Enter 76 then #, you will hear **“One Short Beep”**.
- Step 4** Enter another Function Code to program another parameter otherwise press * to exit and you will hear **“Three Short Beeps”**.

3.16 Function Code 87 Enable or Disable Automatic Call Forwarding

- Step 1** Press 0 and # simultaneously then release. If you are in the programming mode, proceed to step 2.
- Step 2** Enter the 4-digit Master Code (factory default is 0000) and you will hear **“One Short Beep”**. If you entered an invalid master code you will hear **“One Long Beep”**, repeat step 1. Should your master code become lost or forgotten see section 3.3 Reset Master Code.
- Step 3** Enter 87 then #, you will hear **“One Short Beep”**.
- Step 4** Press 1 then # to enable or 0 then # to disable, and you will hear **“One Short Beep”**.

Step 5 Enter another Function Code to program another parameter otherwise press * to exit and you will hear **“Three Short Beeps”**.

3.17 Function Code 88 Select Automatic Call Forwarding Index Number

You can store up to five-call forwarding telephone number (Index 71-75) but you only can enable one at a time.

- Step 5** Press 0 and # simultaneously then release. If you are in the programming mode, proceed to step 2.
- Step 6** Enter the 4-digit Master Code (factory default is 0000) and you will hear **“One Short Beep”**. If you entered an invalid master code you will hear **“One Long Beep”**, repeat step 1. Should your master code become lost or forgotten see section 3.3 Reset Master Code.
- Step 7** Enter 88 then #, you will hear **“One Short Beep”**.
- Step 8** Enter Index Number (71 – 75) then #, you will hear **“One Short Beep”**.
- Step 9** Enter another Function Code to program another parameter otherwise press * to exit and you will hear **“Three Short Beeps”**.

3.18 Function Code 89 Set Automatic Call Forwarding Time

The Automatic Call Forwarding Time can be set 15-90 seconds. The setting is only valid if Function Code 87 is enabled and Function Code 88 is selected and the Aegis 4000 is installed as an intercom system using an existing phone line. For example: If Call Forwarding Time is set for 25 seconds and after the home phone rings for 25 seconds with no answer, the visitor call will be forwarded to the phone number selected on Function Code 88.

- Step 1** Press 0 and # simultaneously then release. If you are in the programming mode, proceed to step 2.
- Step 2** Enter the 4-digit Master Code (factory default is 0000) and you will hear **“One Short Beep”**. If you entered an invalid master code you will hear **“One Long Beep”**, repeat step 1. Should your master code become lost or forgotten see section 3.3 Reset Master Code.
- Step 3** Enter 89 then #, you will hear **“One Short Beep”**.
- Step 4** Select the Automatic Call Forwarding Time (15 – 90 seconds) then #, you will hear **“One Short Beep”**.
Warning: The Automatic Call Forwarding Time must be shorter than the Talk Time programmed on Function Code 91. If the Automatic Call Forwarding Time setting is longer than the Talk Time, the system will abort the call without forwarding the call.
- Step 5** Enter another Function Code to program another parameter otherwise press * to exit and you will hear **“Three Short Beeps”**.

3.19 Function Code 90 Manual Unlock or Lock

This function is to unlock door or gate until you lock it. Door or gate will be closed during a power failure if no battery backup installs on the system. The gate will be opened upon power restores

- Step 1** Press 0 and # simultaneously then release. If you are in the programming mode, proceed to step 2.
- Step 2** Enter the 4-digit Master Code (factory default is 0000) and you will hear **“One Short Beep”**. If you entered an invalid master code you will hear **“One Long Beep”**, repeat step 1. Should your master code become lost or forgotten see section 3.3 Reset Master Code.
- Step 3** Enter 90 then #, you will hear **“One Short Beep”**.
- Step 4** Enter 1 to Unlock and you will hear **“Two Long Beeps”** then **“One Short Beep”**. If the door is already unlocked you will hear **“One Short Beep”** or
Enter 0 to Lock and you will hear **“One Long Beep”** then **“One Short Beep”**.
- Step 5** Enter another Function Code to program another parameter otherwise press * to exit and you will hear **“Three Short Beeps”**.

3.20 Function Code 91 Talk-Time

Is to change the length of talk time between visitor and tenant. The talk-time can be programmed from 10 to 90 seconds. The talk-time is defaulted at 60 seconds. The talk-time timer will start as soon as the AeGIS 4000 is off-hook. Within 10 seconds before the talk-time expires, both tenant and visitor will hear **“One Short Beep”**.

- Step 1** Press 0 and # simultaneously then release. If you are in the programming mode, proceed to step 2.
- Step 2** Enter the 4-digit Master Code (factory default is 0000) and you will hear **“One Short Beep”**. If you entered an invalid master code you will hear **“One Long Beep”**, repeat step 1. Should your master code become lost or forgotten see section 3.3 Reset Master Code.
- Step 3** Enter 91 then #, you will hear **“One Short Beep”**.
- Step 4** Enter the talk-time value (10 – 90 seconds) then press #, you will hear **“One Short Beep”**.
- Step 5** Enter another Function Code to program another parameter otherwise press * to exit and you will hear **“Three Short Beeps”**.

3.21 Function Code 92 Door Open Interval

The door will open according to the door open interval” time period” programmed. The Door open interval can be programmed from 01 – 90 seconds and default at 12 seconds. If the door strike has an independent door strike timer, the Door Open Interval setting is not valid.

- Step 1** Press 0 and # simultaneously then release. If you are in the programming mode, proceed to step 2.
- Step 2** Enter the 4-digit Master Code (factory default is 0000) and you will hear **“One Short Beep”**. If you entered an invalid master code you will hear **“One Long Beep”**, repeat step 1. Should your master code become lost or forgotten see section 3.3 Reset Master Code.
- Step 3** Enter 92 then #, you will hear **“One Short Beep”**.
- Step 4** Enter door open interval value (01 – 90 seconds) then press #, you will hear **“One Short Beep”**.
- Step 5** Enter another Function Code to program another parameter otherwise press * to exit and you will hear **“Three Short Beeps”**.

3.22 Function Code 93 Lock-out Count

After a specific number of times an invalid Access Code has been entered in to the system, the system will ignore further access code entries for 50 seconds and you will hear **“One Long Beep”** every second for 30 seconds. During the lockout condition, the system cannot be used.

- Step 1** Press 0 and # simultaneously then release. If you are in the programming mode, proceed to step 2.
- Step 2** Enter the 4-digit Master Code (factory default is 0000) and you will hear **“One Short Beep”**. If you entered an invalid master code you will hear **“One Long Beep”**, repeat step 1. Should your master code become lost or forgotten see section 3.3 Reset Master Code.
- Step 3** Enter 93 then #, you will hear **“One Short Beep”**.
- Step 4** Enter a new lockout count value (3-9) then press #, you will hear **“One Short Beep”**.
- Step 5** Enter another Function Code to program another parameter otherwise press * to exit and you will hear **“Three Short Beeps”**.

3.23 Function Code 94 Auxiliary Mode

Disabled Mode, Enabled Mode (1): Door will open according to **Door Open Interval** programmed on function code "92" (used for panic bar, postal lock or door switch), **and Enabled Mode (2):** Opening the door is controlled by the AUXIN (used for a timer to open and close the gate according to the timer setting). See figure 2.1 for wiring the AUXIN and also see Chapter 5 System's Operations.

- Step 1** Press 0 and # simultaneously then release. If you are in the programming mode, proceed to step 2.
- Step 2** Enter the 4-digit Master Code (factory default is 0000) and you will hear "**One Short Beep**". If you entered an invalid master code you will hear "**One Long Beep**", repeat step 1. Should your master code become lost or forgotten see section 3.3 Reset Master Code.
- Step 3** Enter 94 then #, you will hear "**One Short Beep**".
- Step 4** Enter **0 (AUXIN is disabled)** or **1 (AUI is enabled and door will open according to Door Open Interval programmed on function Code "92")** or **2 (AUXIN is enabled and opening door is controlled by the AUXIN)** then press #, you will hear "**One Short Beep**".
- Step 5** Enter another Function Code to program another parameter otherwise press * to exit and you will hear "**Three Short Beeps**".

3.24 Function Code 95 Alarm Mode

The alarm mode can be set to **Local Mode** (system's speaker will beep) or **Remote Mode** (call to a premise or remote location), and the system will be disabled for 50 seconds. The alarm will be activated after a specific number of times an invalid access code has been entered as programmed on function code 93. See Chapter 5 System's Operation.

- Step 1** Press 0 and # simultaneously then release. If you are in the programming mode, proceed to step 2.
- Step 2** Enter the 4-digit Master Code (factory default is 0000) and you will hear "**One Short Beep**". If you entered an invalid master code you will hear "**One Long Beep**", repeat step 1. Should your master code become lost or forgotten see section 3.3 Reset Master Code.
- Step 3** Enter 95 then #, you will hear "**One Short Beep**".
- Step 4** Enter **0** for local (system's speaker will beep and the system will be blocked-out for 60 seconds) or **1** (system will make an emergency call to a premise or remote location and the system will be blocked-out for 60 seconds) then press #, you will hear "**One Short Beep**". Refer to Chapter 5 System's Operation.
- Step 5** Enter another Function Code to program another parameter otherwise press * to exit and you will hear "**Three Short Beeps**".

3.25 Function Code 96 System Answer Mode

The system answer mode can be programmed to **Disabled** or **Auto Answer**. If the system answer mode is set to disable, the system will not answer a remote call. If the system answer mode is set to auto answer, the system will answer a remote call in the first ring to the ninth ring, depending on number of ring (s) is programmed. See Chapter 5 System's Operation.

- Step 1** Press 0 and # simultaneously then release. If you are in the programming mode, proceed to step 2.
- Step 2** Enter the 4-digit Master Code (factory default is 0000) and you will hear "**One Short Beep**". If you entered an invalid master code you will hear "**One Long Beep**", repeat step 1. Should your master code become lost or forgotten see section 3.3 Reset Master Code.
- Step 3** Enter 96 then #, you will hear "**One Short Beep**".
- Step 4** Enter **0** (system answer is disabled) or **1, 2, 3 or...9** (system will answer a remote call on 1st ring, 2nd ring, 3rd ring...9th ring) then press # and you will hear "**One Short Beep**".
- Step 5** Enter another Function Code to program another parameter otherwise press * to exit and you will hear "**Three Short Beeps**".

3.26 Function Code 97 Do not Disturb Mode

A Do not Disturb mode can be disabled or enabled through programming. If it's enabled, the system will call to a premise or remote location.

- Step 1** Press 0 and # simultaneously then release. If you are in the programming mode, proceed to step 2.
- Step 2** Enter the 4-digit Master Code (factory default is 0000) and you will hear **"One Short Beep"**. If you entered an invalid master code you will hear **"One Long Beep"**, repeat step 1. Should your master code become lost or forgotten see section 3.3 Reset Master Code.
- Step 3** Enter 97 then #, you will hear **"One Short Beep"**.
- Step 4** Enter 0 to disable **Do not Disturb Mode** (mode 0 is factory default setting) or 1 to enable **Do not Disturb Mode** (system will not call to a premise or remote location) then press #, you will hear **"One Short Beep"**.
- Step 5** Enter another Function Code to program another parameter otherwise press * to exit and you will hear **"Three Short Beep"**.

3.27 Function Code 98 Select Initiating Premise Call Key # or *

By default the # key is used to call the AeGIS 4000 from your home phone. In some area the # key does not work and the * can be used as a substitution.

- Step 1** Press 0 and # simultaneously then release. If you are in the programming mode, proceed to step 2.
- Step 2** Enter the 4-digit Master Code (factory default is 0000) and you will hear **"One Short Beep"**. If you entered an invalid master code you will hear **"One Long Beep"**, repeat step 1. Should your master code become lost or forgotten see section 3.3 Reset Master Code.
- Step 3** Enter 98 then #, you will hear **"One Short Beep"**.
- Step 4** Enter 0 to use # key or 1 to use * then press #, you will hear **"One Short Beep"**.
- Step 5** Enter another Function Code to program another parameter otherwise press * to exit and you will hear **"Three Short Beeps"**.

3.28 Function Code 99 Set Memory to Factory Default

Is to clear system's database and the entire configuration will return to factory default. You may consult our technical department before using this code.

- Step 1** Press 0 and # simultaneously then release. If you are in the programming mode, proceed to step 2.
- Step 2** Enter the 4-digit Master Code (factory default is 0000) and you will hear **"One Short Beep"**. If you entered an invalid master code you will hear **"One Long Beep"**, repeat step 1. Should your master code become lost or forgotten see section 3.3 Reset Master Code.
- Step 3** Enter 99 then #, you will hear **"Two Long Beeps"**.
- Step 4** Enter 0 then # to cancel and you will hear **"One short beep"** or 1 then # to clear the system's database and entire configuration to factory default and you will hear **"Three short beeps"**.
- Step 5** Enter another Function Code to program another parameter otherwise press * to exit and you will hear **"Three Short Beeps"**.

Chapter 4. Remote Programming from Premise Location

The AeGIS 4000 can be programmed remotely from a **premise (home phone)** for your convenience. Some of the parameters and function codes cannot be programmed remotely for security purposes. You must follow the requirements below to do the remote programming:

- Active telephone line (Telephone Central Office) must be connected to pin T and R (phone CO) on the interceptor module, see figure 2.1.
- A touch-tone phone must be used.
- The system answer mode must be enabled (Function Code 96).

NOTE: The remote programming feature cannot be used if no active telephone line (CO) is connected to T and R (phone CO) on the interceptor module.

or ****** is used to call the AeGIS 4000 from your home phone. See Function Code 98 to select the **#** or ******. The instructions below show the **# #** key is used to call the AeGIS from your home phone. If ***** is used, substitute the **# #** with ****** on **Step 2** on each section.

4.1 Add Individual Access Code (Index Number 01-50)

You can program up to 50 individual access codes.

NOTE: The connection will be disconnected if it idles for 30 seconds.

- Step 1** Pick up the phone and wait for dial tone.
- Step 2** Press **# #** and you will hear **“One Short Beep”**.
- Step 3** Press **#** and you will hear **“One Short Beep”**.
- Step 4** Enter the 01, 02,...or 50 then press **#**, you will hear
“No Beep”: the index numbers is empty and proceed to Step 5.
“Two Long Beeps”: the index number is not empty and you must do one of the following:
- Press 1 then **#** you will hear **“No Beep”** to overwrite existing access code and proceed to Step 4.
 - Press ****** you will **“One Short Beep”** and repeat this step.
- Step 5** Enter the 4-digit access code number then press **#**, you will hear **“One Short Beep”**.
- Step 6** Return to step 4 to program another access code or enter another function code to program different parameter or exit the program by pressing ****** and you will hear **“Three Short Beeps”**

4.2 Delete Individual Access Code (Function Code 60 – 64)

You can delete the access code in a group of ten. For example: Function Code 60 is to delete the access codes programmed on index number 01 – 10 and Function Code 61 is to delete the access codes programmed on index number 11 – 20. See Chapter 3 Programming.

- Step 1** Pick up the phone and wait for dial tone.
- Step 2** Press **# #** and you will hear **“One Short Beep”**.
- Step 3** Press **#** and you will hear **“One Short Beep”**.
- Step 4** Enter 60 or 61, or ... 64 then press **#**, you will hear **“One Short Beep”**.
- Step 5** Return to step 4 to delete another group of access codes or enter another function code to program different parameter or exit the program by pressing ****** and you will hear **“Three Short Beeps”**.

4.3 Delete All Access Codes (Function Code 65)

The Function Code will delete all access codes on index number 01 – 50.

- Step 1** Pick up the phone and wait for dial tone.
- Step 2** Press # # and you will hear *“One Short Beep”*.
- Step 3** Press # and you will hear *“One Short Beep”*.
- Step 4** Enter 65 then press #, you will hear *“One Short Beep”*.
- Step 5** Enter another function code to program different parameter or exit the program by pressing * * and you will hear *“Three Short Beeps”*.

4.4 Non-Indexed Call Forwarding (Function Code 70)

The Non-Indexed Call Forwarding will be activated automatically if a telephone number is programmed on index number 70.

4.4.1 Add Non-Indexed Call Forwarding

- Step 1** Pick up the phone and wait for dial tone.
- Step 2** Press # # and you will hear *“One Short Beep”*.
- Step 3** Press # and you will hear *“One Short Beep”*.
- Step 4** Enter 70 then press #, you will hear *“No Beep”*.
- Step 5** Enter the non-indexed call forwarding phone number up to 11-digit you will hear *“One Short Beep”*.
- Step 6** Enter another function code to program a different parameter or exit the program by pressing * * and you will hear *“Three Short Beeps”*.

4.4.2 Delete Non-Indexed Call Forwarding

- Step 1** Pick up the phone and wait for dial tone.
- Step 2** Press # # and you will hear *“One Short Beep”*.
- Step 3** Press 6 and you will hear *“Three Short Beeps”*, and the system disconnects the call.

4.5 Indexed Call Forwarding (Function Code 71 – 75)

You may add, delete and over write the indexed call forwarding. The Function Code 71-75 can also be called Index Number71-75.

4.5.1 Add Indexed Call Forwarding

- Step 1** Pick up the phone and wait for a dial tone.
- Step 2** Press # # and you will hear *“One Short Beep”*.
- Step 3** Press # and you will hear *“One Short Beep”*.
- Step 4** Enter the Function Code or index number “71” or “72” or ... “75” then press #, you will hear *“No Beep”*. If you hear *“Two Long Beeps”*, the Index Number has an associated phone number programmed. Press *, you will hear *“One Short Beep”* and select another Index Number (71 – 75).
- Step 5** Enter the indexed call forwarding number up to 11-digit.
- Step 6** Enter another function code to program a different parameter or exit the program by pressing * * and you will hear *“Three Short Beeps”*.

4.5.2 Delete Existing Indexed Call Forwarding

- Step 1** Pick up the phone and wait for a dial tone.
- Step 2** Press # # and you will hear *“One Short Beep”*.
- Step 3** Press # and you will hear *“One Short Beep”*.

- Step 4** Enter the Function Code or index number "71" or "72" or ... "75" then press #, you will hear "**Two Long Beeps**"; means the Index Number has an associated phone number, proceed to step5. If you hear "**No Beep**", means the indexed number does not have an associated phone number, press * and continue step 4 or proceed to step 6.
- Step 5** Press "0" and #, you will hear "**One Short Beep**" and phone number associated with the indexed number is deleted.
- Step 6** Enter another function code to program a different parameter or exit the program by pressing * * and you will hear "**Three Short Beeps**".

4.5.3 Rewrite Existing Indexed Call Forwarding

- Step 1** Pick up the phone and wait for a dial tone.
- Step 2** Press # # and you will hear "**One Short Beep**".
- Step 3** Press # and you will hear "**One Short Beep**".
- Step 4** Enter the Function Code or index number you want to over write "71" or "72" or ... "75" then press #, you will hear "**Two Long Beeps**", means the Index Number has an associated phone number, proceed to step 5. If you hear "**No Beep**", the index number does not have an associated phone number, press * and continue step 4 or proceed to step 6
- Step 5** Press "1" then press # you will hear "**No Beep**" and enter a new phone number up to 11-digit then press #, you will hear "**One Short Beep**".
- Step 6** Enter another function code to program a different parameter or exit the program by pressing * * and you will hear "**Three Short Beeps* ***".

4.6 Delete All Call Forwarding Phone Number (Function Code 76)

- Step 1** Pick up the phone and wait for a dial tone.
- Step 2** Press # # and you will hear "**One Short Beep**".
- Step 3** Press # and you will hear "**One Short Beep**".
- Step 4** Enter the Function Code 76 then press #, you will hear "**One Short Beep**".
- Step 5** Enter another function code to program a different parameter or exit the program by pressing * * and you will hear "**Three Short Beeps**".

4.7 Enable or Disable Automatic Call Forwarding (Function Code 87)

The Automatic Call Forwarding is automatically enabled if the phone number is programmed on Index 71. See also operation.

- Step 1** Pick up the phone and wait for a dial tone.
- Step 2** Press # # and you will hear "**One Short Beep**".
- Step 3** Press # and you will hear "**One Short Beep**".
- Step 4** Press 87 then #, you will hear "**One Short Beep**".
- Step 5** Press 1 (to enable) then press #, you will hear "**One Short Beep**" or Press 0 (to disable) then press #, you will hear "**One Short Beep**".
- Step 6** Enter another function code to program a different parameter or exit the program by pressing * * and you will hear "**Three Short Beeps**".

4.8 Selecting Automatic Call Forwarding Index Number (Function Code 88)

The Automatic Call Forwarding phone number is programmed on Index 71-75. The Automatic Call forwarding is enabled automatically if a phone number is programmed on Index 71.

- Step 1** Pick up the phone and wait for a dial tone.
- Step 2** Press # # and you will hear "**One Short Beep**".

- Step 3** Press # and you will hear **“One Short Beep”**.
- Step 4** Press 88 then #, you will hear **“One Short Beep”**.
- Step 5** Press 71-75 then press #, you will hear **“One Short Beep”**.
- Step 6** Enter another function code to program a different parameter or exit the program by pressing * * and you will hear **“Three Short Beeps”**.

4.9 Set Automatic Call Forwarding Time (Function Code 89)

The Automatic Call Forwarding Time must be programmed shorter than the Talk Time programmed on Function Code 91. The AeGIS 4000 call will be forwarded to the phone number programmed on Index 71-75 after the Call Forwarding Time is expired. The Call Forwarding Time must be shorter than the Talk Time programmed on Function Code 91, otherwise the Automatic Call Forwarding will not work.

- Step 1** Pick up the phone and wait for a dial tone.
- Step 2** Press # # and you will hear **“One Short Beep”**.
- Step 3** Press # and you will hear **“One Short Beep”**.
- Step 4** Press 89 then #, you will hear **“One Short Beep”**.
- Step 5** Press 15-90 (15 seconds-90 seconds) then press #, you will hear **“One Short Beep”**.
- Step 6** Enter another function code to program a different parameter or exit the program by pressing * * and you will hear **“Three Short Beeps”**.

4.10 Unlock or Lock Door or Gate (Function Code 90)

- Step 1** Pick up the phone and wait for a dial tone.
- Step 2** Press # # and you will hear **“One Short Beep”**.
- Step 3** Press # and you will hear **“One Short Beep”**.
- Step 4** Press 90 then #, you will hear **“One Short Beep”**.
- Step 5** Press 1 (to unlock hold) then press #, you will hear **“Two Long Beeps”** then **“One Short Beep”**. If you hear **“One Short Beep”**, means the door is unlocked or Press 0 (to lock) then press #, you will hear **“One Long Beep”** then **“One Short Beep”**.
- Step 6** Enter another function code to program a different parameter or exit the program by pressing * * and you will hear **“Three Short Beeps”**.

4.11 Talk Time (Function Code 91)

- Step 1** Pick up the phone and wait for a dial tone.
- Step 2** Press # # and you will hear **“One Short Beep”**.
- Step 3** Press # and you will hear **“One Short Beep”**.
- Step 4** Enter the Function Code 91 then press #, you will hear **“One Short Beep”**.
- Step 5** Enter the talk time (10 –90 seconds) then press #, you will hear **“One Short Beep”**.
- Step 6** Enter another function code to program a different parameter or exit the program by pressing * * and you will hear **“Three Short Beeps”**.

4.12 Door Open Interval (Function Code 92)

- Step 1** Pick up the phone and wait for a dial tone.
- Step 2** Press # # and you will hear **“One Short Beep”**.
- Step 3** Press # and you will hear **“One Short Beep”**.
- Step 4** Enter the Function Code 92 then press #, you will hear **“One Short Beep”**.
- Step 5** Enter door open interval (04 – 90 seconds) then press #, you will hear **“One Short Beep”**.
- Step 6** Enter another function code to program a different parameter or exit the program by pressing * * and you will hear **“Three Short Beeps”**.

4.13 Lock-Out Count (Function Code 93)

- Step 1** Pick up the phone and wait for a dial tone.
- Step 2** Press # # and you will hear ***“One Short Beep”***.
- Step 3** Press # and you will hear ***“One Short Beep”***.
- Step 4** Enter the Function Code 93 then press #, you will hear ***“One Short Beep”***.
- Step 5** Enter the lockout count (03 – 09) then press #, you will hear ***“One Short Beep”***.
- Step 6** Enter another function code to program a different parameter or exit the program by pressing * * and you will hear ***“Three Short Beeps”***.

4.14 Auxiliary Mode (Function Code 94)

- Step 1** Pick up the phone and wait for a dial tone.
- Step 2** Press # # and you will hear ***“One Short Beep”***.
- Step 3** Press # and you will hear ***“One Short Beep”***.
- Step 4** Enter the Function Code 94 then press #, you will hear ***“One Short Beep”***.
- Step 5** Enter (0 = AUI is disabled or 1 = AUI is enabled, door open time is control by door open interval programmed on function code 92, or 2 = AUI is enabled, door open time is controlled by the AUI) then press #, you will hear ***“One Short Beep”***.
- Step 6** Enter another function code to program a different parameter or exit the program by pressing * * and you will hear ***“Three Short Beeps”***.

4.15 Alarm Mode (Function Code 95)

- Step 1** Pick up the phone and wait for a dial tone.
- Step 2** Press # # and you will hear ***“One Short Beep”***.
- Step 3** Press # and you will hear ***“One Short Beep”***.
- Step 4** Enter the Function Code 95 then press #, you will hear ***“One Short Beep”***.
- Step 5** Enter (0 = the system will beep via its speaker or 1 = the system will call into a premise or remote location) then press #, you will hear ***“One Short Beep”***.
- Step 6** Enter another function code to program a different parameter or exit the program by pressing * * and you will hear ***“Three Short Beeps”***.

4.16 System Answer Mode (Function Code 96)

The system number of rings to answer a remote call can be programmed from 1 to 9 rings or it can also be disabled. You must program the System Answer Mode at the front panel

4.17 Do not Disturb Mode (Function Code 97)

- Step 1** Pick up the phone and wait for a dial tone.
- Step 2** Press # # and you will hear ***“One Short Beep”***.
- Step 3** Press # and you will hear ***“One Short Beep”***.
- Step 4** Enter the Function Code 97 then press #, you will hear ***“One Short Beep”***.
- Step 5** Enter 0 (to disable) or 1 (to enable) then press #, you will hear ***“One Short Beep”***.
- Step 6** Enter another function code to program a different parameter or exit the program by pressing * * and you will hear ***“Three Short Beeps”***.

4.18 Select Initiating Premise Call Key # or * (Function Code 98)

- Step 1** Pick up the phone and wait for a dial tone.
- Step 2** Press # # and you will hear ***“One Short Beep”***.
- Step 3** Press # and you will hear ***“One Short Beep”***.
- Step 4** Enter the Function Code 98 then press #, you will hear ***“One Short Beep”***.
- Step 5** Enter 0 (to select #) or 1 (to select *) then press #, you will hear ***“One Short Beep”***.
- Step 6** Enter another function code to program a different parameter or exit the program by pressing * * and you will hear ***“Three Short Beeps”***.

4.19 Set Memory to Factory Default

It must be done at the control panel.

Chapter 5. Remote Programming from Remote Location

Telephone remote programming from a remote location is identical to premise remote programming, except a valid master code must be used to logon to programming mode. Follow the steps below to log in to the programming mode:

5.1 Add Individual Access Code (Index Number 01-50)

- Step 1** Call to the AeGIS 4000 system (you must know the system's phone number), you will hear:
"One Short Beep", the gate is locked.
"Two Short Beeps", the gate is unlocked.
- Step 2** Press # then enter a valid master code and you will hear:
"One Short Beep", the master code is accepted then press # and you will hear "One Short Beep".
"One Long Beep", the master code is rejected and the connection will be disconnected.
- Step 3** Press # to enter into the programming mode and you will hear "One Short Beep" or ** to hang-up the call.
- Step 4** Enter the 01, 02,...or 50 then press #, you will hear
"No Beep": the index numbers is empty and proceed to Step 5.
"Two Long Beeps": the index number is not empty and you must do one of the following:
- Press 1 then # you will hear "No Beep" to overwrite existing access code and proceed to Step 4.
 - Press * * you will "One Short Beep" and repeat this step.
- Step 5** Enter the 4-digit access code number then press #, you will hear "One Short Beep".
- Step 6** Return to step 4 to program another access code or enter another function code to program different parameter or exit the program by pressing * * and you will hear "Three Short Beeps"

NOTE: The connection will be disconnected if the system idles for 30 seconds

5.2 Delete Individual Access Code (Function Code 60 – 64)

You can delete the access code in a group of ten. For example: Function Code 60 is to delete the access codes programmed on index number 01 – 10 and Function Code 61 is to delete the access codes programmed on index number 11 – 20. See Chapter 3 Programming.

- Step 1** Call to the AeGIS 4000 system (you must know the system's phone number), you will hear:
"One Short Beep", the gate is locked.
"Two Short Beeps", the gate is unlocked.
- Step 2** Press # then enter a valid master code and you will hear:
"One Short Beep", the master code is accepted then press # and you will hear "One Short Beep".
"One Long Beep", the master code is rejected and the connection will be disconnected.
- Step 3** Press # to enter into the programming mode and you will hear "One Short Beep" or ** to hang-up the call.
- Step 4** Enter 60 or 61, or ... 64 then press #, you will hear "One Short Beep".
- Step 5** Return to step 4 to delete another group of access codes or enter another function code to program different parameter or exit the program by pressing * * and you will hear "Three Short Beeps".

5.3 Delete All Access Codes (Function Code 65)

The Function Code will delete all access codes on index number 01 – 50.

- Step 1** Call to the AeGIS 4000 system (you must know the system's phone number), you will hear:
"One Short Beep", the gate is locked.
"Two Short Beeps", the gate is unlocked.

- Step 2** Press # then enter a valid master code and you will hear:
“One Short Beep”, the master code is accepted then press # and you will hear *“One Short Beep”*.
“One Long Beep”, the master code is rejected and the connection will be disconnected.
- Step 3** Press # to enter into the programming mode and you will hear *“One Short Beep”* or ** to hang-up the call.
- Step 4** Enter 65 then press #, you will hear *“One Short Beep”*.
- Step 5** Enter another function code to program different parameter or exit the program by pressing * * and you will hear *“Three Short Beeps”*.

5.4 Non-Indexed Call Forwarding (Function Code 70)

The Non-Indexed Call Forwarding will be activated automatically if a telephone number is programmed on index number 70.

5.4.1 Add Non-Indexed Call Forwarding

- Step 1** Call to the AeGIS 4000 system (you must know the system’s phone number), you will hear:
“One Short Beep”, the gate is locked.
“Two Short Beeps”, the gate is unlocked.
- Step 2** Press # then enter a valid master code and you will hear:
“One Short Beep”, the master code is accepted then press # and you will hear *“One Short Beep”*.
“One Long Beep”, the master code is rejected and the connection will be disconnected.
- Step 3** Press # to enter into the programming mode and you will hear *“One Short Beep”* or ** to hang-up the call.
- Step 4** Enter 70 then press #, you will hear *“No Beep”*.
- Step 5** Enter the non-indexed call forwarding phone number up to 11-digit you will hear *“One Short Beep”*.
- Step 6** Enter another function code to program a different parameter or exit the program by pressing * * and you will hear *“Three Short Beeps”*.

5.4.2 Delete Non-Indexed Call Forwarding

- Step 1** Call to the AeGIS 4000 system (you must know the system’s phone number), you will hear:
“One Short Beep”, the gate is locked.
“Two Short Beeps”, the gate is unlocked.
- Step 2** Press # then enter a valid master code and you will hear:
“One Short Beep”, the master code is accepted then press # and you will hear *“One Short Beep”*.
“One Long Beep”, the master code is rejected and the connection will be disconnected.
- Step 3** Press 6, you will hear *“Three Short Beeps”* and the system disconnects the call.

5.5 Indexed Call Forwarding (Function Code 71 – 75)

You may add, delete and over write the indexed call forwarding. The Function Code 71-75 can also be called Index Number71-75.

5.5.1 Add Indexed Call Forwarding

- Step 1** Call to the AeGIS 4000 system (you must know the system’s phone number), you will hear:
“One Short Beep”, the gate is locked.
“Two Short Beeps”, the gate is unlocked.
- Step 2** Press # then enter a valid master code and you will hear:
“One Short Beep”, the master code is accepted then press # and you will hear *“One Short Beep”*.
“One Long Beep”, the master code is rejected and the connection will be disconnected.

- Step 3** Press # to enter into the programming mode and you will hear **“One Short Beep”** or ** to hang-up the call.
- Step 4** Enter the Function Code or index number “71” or “72” or ... “75” then press #, you will hear **“No Beep”**. If you hear **“Two Long Beeps”**, the Index Number has an associated phone number programmed. Press *, you will hear **“One Short Beep”** and select another Index Number (71 – 75).
- Step 5** Enter the indexed call forwarding number up to 11-digit.
- Step 6** Enter another function code to program a different parameter or exit the program by pressing * * and you will hear **“Three Short Beeps”**.

5.5.2 Delete Existing Indexed Call Forwarding

- Step 1** Call to the AeGIS 4000 system (you must know the system’s phone number), you will hear:
“One Short Beep”, the gate is locked.
“Two Short Beeps”, the gate is unlocked.
- Step 2** Press # then enter a valid master code and you will hear:
“One Short Beep”, the master code is accepted then press # and you will hear **“One Short Beep”**.
“One Long Beep”, the master code is rejected and the connection will be disconnected.
- Step 3** Press # to enter into the programming mode and you will hear **“One Short Beep”** or ** to hang-up the call.
- Step 4** Enter the Function Code or index number “71” or “72” or ... “75” then press #, you will hear **“Two Long Beeps”**; means the Index Number has an associated phone number, proceed to step5. If you hear **“No Beep”**, means the indexed number does not have an associated phone number, press * and continue step 4 or proceed to step 6.
- Step 5** Press “0” and #, you will hear **“One Short Beep”** and phone number associated with the indexed number is deleted.
- Step 6** Enter another function code to program a different parameter or exit the program by pressing * * and you will hear **“Three Short Beeps”**.

5.5.3 Rewrite Existing Indexed Call Forwarding

- Step 1** Call to the AeGIS 4000 system (you must know the system’s phone number), you will hear:
“One Short Beep”, the gate is locked.
“Two Short Beeps”, the gate is unlocked.
- Step 2** Press # then enter a valid master code and you will hear:
“One Short Beep”, the master code is accepted then press # and you will hear **“One Short Beep”**.
“One Long Beep”, the master code is rejected and the connection will be disconnected.
- Step 3** Press # to enter into the programming mode and you will hear **“One Short Beep”** or ** to hang-up the call.
- Step 4** Enter the Function Code or index number you want to over write “71” or “72” or ... “75” then press #, you will hear **“Two Long Beeps”**, means the Index Number has an associated phone number, proceed to step 5. If you hear **“No Beep”**, the index number does not have an associated phone number, press * and continue step 4 or proceed to step 6
- Step 5** Press “1” then press # you will hear **“No Beep”** and enter a new phone number up to 11-digit then press #, you will hear **“One Short Beep”**.
- Step 6** Enter another function code to program a different parameter or exit the program by pressing * * and you will hear **“Three Short Beeps* *”**.

5.6 Delete all Call Forwarding Phone Number (Function Code 76)

- Step 1** Call to the AeGIS 4000 system (you must know the system's phone number), you will hear:
"One Short Beep", the gate is locked.
"Two Short Beeps", the gate is unlocked.
- Step 2** Press # then enter a valid master code and you will hear:
"One Short Beep", the master code is accepted then press # and you will hear "One Short Beep".
"One Long Beep", the master code is rejected and the connection will be disconnected.
- Step 3** Press # to enter into the programming mode and you will hear "One Short Beep" or ** to hang-up the call.
- Step 4** Enter the Function Code 76 then press #, you will hear "One Short Beep".
- Step 5** Enter another function code to program a different parameter or exit the program by pressing * * and you will hear "Three Short Beeps".

5.7 Enable or Disable Automatic Call Forwarding (Function Code 87)

The Automatic Call Forwarding is automatically enabled if the phone number is programmed on Index 71. See also operation.

- Step 1** Call to the AeGIS 4000 system (you must know the system's phone number), you will hear:
"One Short Beep", the gate is locked.
"Two Short Beeps", the gate is unlocked.
- Step 2** Press # then enter a valid master code and you will hear:
"One Short Beep", the master code is accepted then press # and you will hear "One Short Beep".
"One Long Beep", the master code is rejected and the connection will be disconnected.
- Step 3** Press # to enter into the programming mode and you will hear "One Short Beep" or ** to hang-up the call.
- Step 4** Press 1 (to enable) then press #, you will hear "One Short Beep" or
Press 0 (to disable) then press #, you will hear "One Short Beep".
- Step 5** Enter another function code to program a different parameter or exit the program by pressing * * and you will hear "Three Short Beeps".

5.8 Selecting Automatic Call Forwarding Index Number (Function Code 88)

The Automatic Call Forwarding phone number is programmed on Index 71-75. The Automatic Call forwarding is enabled automatically if a phone number is programmed on Index 71.

- Step 1** Call to the AeGIS 4000 system (you must know the system's phone number), you will hear:
"One Short Beep", the gate is locked.
"Two Short Beeps", the gate is unlocked.
- Step 2** Press # then enter a valid master code and you will hear:
"One Short Beep", the master code is accepted then press # and you will hear "One Short Beep".
"One Long Beep", the master code is rejected and the connection will be disconnected.
- Step 3** Press # to enter into the programming mode and you will hear "One Short Beep" or ** to hang-up the call.
- Step 4** Press 88 then #, you will hear "One Short Beep".
- Step 5** Press 71-75 then press #, you will hear "One Short Beep".
- Step 6** Enter another function code to program a different parameter or exit the program by pressing * * and you will hear "Three Short Beeps".

5.9 Set Automatic Call Forwarding Time (Function Code 89)

The Automatic Call Forwarding Time must program shorter than the Talk Time programmed on Function Code 91. The AeGIS 4000 call will be forwarded to the phone number programmed on Index 71-75 after the Call Forwarding Time is expired. The Call Forwarding Time must be shorter than the Talk Time programmed on Function Code 91, otherwise the Automatic Call Forwarding will not work.

- Step 1** Call to the AeGIS 4000 system (you must know the system's phone number), you will hear:
"One Short Beep", the gate is locked.
"Two Short Beeps", the gate is unlocked.
- Step 2** Press # then enter a valid master code and you will hear:
"One Short Beep", the master code is accepted then press # and you will hear "One Short Beep".
"One Long Beep", the master code is rejected and the connection will be disconnected.
- Step 3** Press 89 then #, you will hear "One Short Beep".
- Step 4** Press 15-90 (15 seconds-90 seconds) then press #, you will hear "One Short Beep".
- Step 5** Enter another function code to program a different parameter or exit the program by pressing * * and you will hear "Three Short Beeps".

5.10 Unlock or Lock Door or Gate (Function Code 90)

- Step 1** Call to the AeGIS 4000 system (you must know the system's phone number), you will hear:
"One Short Beep", the gate is locked.
"Two Short Beeps", the gate is unlocked.
- Step 2** Press # then enter a valid master code and you will hear:
"One Short Beep", the master code is accepted then press # and you will hear "One Short Beep".
"One Long Beep", the master code is rejected and the connection will be disconnected.
- Step 3** Press 90 then #, you will hear "One Short Beep".
- Step 4** Press 1 (to unlock hold) then press #, you will hear "Two Long Beeps" then "One Short Beep". If you hear "One Short Beep", means the door is unlocked or
Press 0 (to lock) then press #, you will hear "One Long Beep" then "One Short Beep".
- Step 5** Enter another function code to program a different parameter or exit the program by pressing * * and you will hear "Three Short Beeps".

5.11 Talk Time (Function Code 91)

- Step 1** Call to the AeGIS 4000 system (you must know the system's phone number), you will hear:
"One Short Beep", the gate is locked.
"Two Short Beeps", the gate is unlocked.
- Step 2** Press # then enter a valid master code and you will hear:
"One Short Beep", the master code is accepted then press # and you will hear "One Short Beep".
"One Long Beep", the master code is rejected and the connection will be disconnected.
- Step 3** Enter the Function Code 91 then press #, you will hear "One Short Beep".
- Step 4** Enter the talk time (10 –90 seconds) then press #, you will hear "One Short Beep".
- Step 5** Enter another function code to program a different parameter or exit the program by pressing * * and you will hear "Three Short Beeps".

5.12 Door Open Interval (Function Code 92)

- Step 1** Call to the AeGIS 4000 system (you must know the system's phone number), you will hear:
"One Short Beep", the gate is locked.
"Two Short Beeps", the gate is unlocked.
- Step 2** Press # then enter a valid master code and you will hear:

“One Short Beep”, the master code is accepted then press # and you will hear **“One Short Beep”**.

“One Long Beep”, the master code is rejected and the connection will be disconnected.

- Step 3** Enter the Function Code 92 then press #, you will hear **“One Short Beep”**.
- Step 4** Enter door open interval (04 – 90 seconds) then press #, you will hear **“One Short Beep”**.
- Step 5** Enter another function code to program a different parameter or exit the program by pressing * * and you will hear **“Three Short Beeps”**.

5.13 Lock-Out Count (Function Code 93)

- Step 1** Call to the AeGIS 4000 system (you must know the system’s phone number), you will hear:
“One Short Beep”, the gate is locked.
“Two Short Beeps”, the gate is unlocked.
- Step 2** Press # then enter a valid master code and you will hear:
“One Short Beep”, the master code is accepted then press # and you will hear **“One Short Beep”**.
“One Long Beep”, the master code is rejected and the connection will be disconnected.
- Step 3** Enter the Function Code 93 then press #, you will hear **“One Short Beep”**.
- Step 4** Enter the lockout count (03 – 09) then press #, you will hear **“One Short Beep”**.
- Step 5** Enter another function code to program a different parameter or exit the program by pressing * * and you will hear **“Three Short Beeps”**.

5.14 Auxiliary Mode (Function Code 94)

- Step 1** Call to the AeGIS 4000 system (you must know the system’s phone number), you will hear:
“One Short Beep”, the gate is locked.
“Two Short Beeps”, the gate is unlocked.
- Step 2** Press # then enter a valid master code and you will hear:
“One Short Beep”, the master code is accepted then press # and you will hear **“One Short Beep”**.
“One Long Beep”, the master code is rejected and the connection will be disconnected.
- Step 3** Enter the Function Code 94 then press #, you will hear **“One Short Beep”**.
- Step 4** Enter (0 = AUI is disabled or 1 = AUI is enabled, door open time is control by door open interval programmed on function code 92, or 2 = AUI is enabled, door open time is controlled by the AUI) then press #, you will hear **“One Short Beep”**.
- Step 5** Enter another function code to program a different parameter or exit the program by pressing * * and you will hear **“Three Short Beeps”**.

5.15 Alarm Mode (Function Code 95)

- Step 1** Call to the AeGIS 4000 system (you must know the system’s phone number), you will hear:
“One Short Beep”, the gate is locked.
“Two Short Beeps”, the gate is unlocked.
- Step 2** Press # then enter a valid master code and you will hear:
“One Short Beep”, the master code is accepted then press # and you will hear **“One Short Beep”**.
“One Long Beep”, the master code is rejected and the connection will be disconnected.
- Step 3** Enter the Function Code 95 then press #, you will hear **“One Short Beep”**.
- Step 4** Enter (0 = the system will beep via its speaker or 1 = the system will call into a premise or remote location) then press #, you will hear **“One Short Beep”**.
- Step 5** Enter another function code to program a different parameter or exit the program by pressing * * and you will hear **“Three Short Beeps”**.

5.16 System Answer Mode (Function Code 96)

The system number of rings to answer a remote call can be programmed from 1 to 9 rings or it can also be disabled. You must program the System Answer Mode at the front panel

5.17 Do not Disturb Mode (Function Code 97)

- Step 1** Call to the AeGIS 4000 system (you must know the system's phone number), you will hear:
 "One Short Beep", the gate is locked.
 "Two Short Beeps", the gate is unlocked.
- Step 2** Press # then enter a valid master code and you will hear:
 "One Short Beep", the master code is accepted then press # and you will hear *"One Short Beep"*.
 "One Long Beep", the master code is rejected and the connection will be disconnected.
- Step 3** Enter the Function Code 97 then press #, you will hear *"One Short Beep"*.
- Step 4** Enter 0 (to disable) or 1 (to enable) then press #, you will hear *"One Short Beep"*.
- Step 5** Enter another function code to program a different parameter or exit the program by pressing * * and you will hear *"Three Short Beeps"*.

5.18 Select Initiating Premise Call Key # or * (Function Code 98)

- Step 1** Call to the AeGIS 4000 system (you must know the system's phone number), you will hear:
 "One Short Beep", the gate is locked.
 "Two Short Beeps", the gate is unlocked.
- Step 2** Press # then enter a valid master code and you will hear:
 "One Short Beep", the master code is accepted then press # and you will hear *"One Short Beep"*.
 "One Long Beep", the master code is rejected and the connection will be disconnected.
- Step 3** Enter the Function Code 98 then press #, you will hear *"One Short Beep"*.
- Step 4** Enter 0 (to select #) or 1 (to select *) then press #, you will hear *"One Short Beep"*.
- Step 5** Enter another function code to program a different parameter or exit the program by pressing * * and you will hear *"Three Short Beeps"*.

5.19 Set the Memory to Factory Default

It must be done at the control panel.

Chapter 6. System's Operations

It is important for you to understand the system's operations completely for the most ease of operations. You can enable or disable the system programming *remotely via a touch-tone phone* or *locally via the system's keypad*.

6.1 How to Initiate Call from the AeGIS 4000

Press # to initiate a call to a premise or remote location, and you will hear:

"A Ring Back " until the called is answered or the system's timer is expired (see function code 91). If you decide to abort the call, press *.

6.2 How to Answer the AeGIS 4000 Call and Extend the Talk Time

Tenant will hear **double rings (distinctive ringing)** if the AeGIS 4000 calls to a premise. No distinctive ringing will be heard if the AeGIS calls to a remote location.

Step 1 Answer the AeGIS calls.

Step 2 Talk to your visitor, you will hear **"One Short Beep"** 10 seconds before the talk time expired, press # to extend the talk time to another cycle. Press 9 to provide access, you will hear **"Two Short Beeps"** or hang up if you do not want to provide access to your visitor.

6.3 How to Provide Access to Visitor

Connection must be established then tenant needs to press **9** to provide access to visitor and you will hear **"Two Short Beeps"**.

6.4 How to Use Call Waiting Feature

The AeGIS 4000 has built-in call waiting feature. You may not be able to tell the different between the AeGIS's call waiting beeps and the phone company call waiting beeps.

If you are connected to an outside line and receive a call from the AeGIS 4000:

Step 1 You will hear **"Three Sets of a Short Beep"** with three seconds delay between them (indicates you have an incoming call from the AeGIS 4000). **Do Not Hang-up, Doing So Will Disconnect Both Calls.**

Step 2 **Press *** to disconnect the outside call and now you are connected to the AeGIS or **Press "0"** to put the outside calls on hold and you will hear **"Three Sets of Two Short Beep"** with three seconds delay between them (indicates you have a call holding on the outside line).

Step 3 Press 9 to provide access to your visitor or * to hang-up with the AeGIS and you will be automatically switched to the original call.

If you are connected with the AeGIS 4000 and receive an outside call:

Step 1 You will hear **"Three Sets of Three Short Beeps"** with three seconds delay between them (indicates you have an incoming call from the outside line). **Do Not Hang-up, Doing So Will Disconnect Both Calls.**

Step 2 **Press 9** to provide access to your visitor or **Press *** to disconnect the AeGIS calls and you are connected to the outside calls or **Press "0"** to put the AeGIS calls on hold and you will hear **"Three Sets of a Short Beep"** with three seconds delay between them, indicates you have a call holding.

6.5 How to Use Personal Access Code

The Non-restricted personal access code (4-digit code) is used to open door or gate from the AeGIS 4000 system without using a key. The personal access code can be used for tenants, members of family or maintenance person to open door or gate. You can program a maximum of 50 (4-digit) different access codes. You can program the access code local (using the control panel keypad) or remote via a touch-tone phone; refer to Chapter 3, 4 and 5.

NOTE: The number of times an invalid access code can be entered before the system goes into the **lockout mode** depends on the programming on Function Code 93 (Lockout Count). The system will **lockout** and go into an **alarm mode** after you have entered a specific number of invalid access codes sets on Function Code 93. The **alarm mode** can be set into two modes: **local alarm** and **remote alarm** (refer to Chapter 3 Function Code 95 Alarm Mode)

Press * then a 4-digit access code.

- Hear **“Two Long Beeps”** and the gate will open (means your access code is accepted by the system).
- Hear **“One Long Beep”** and the gate will not open (means your access code is denied and try again).

NOTE: The system will be blocked for 60 seconds after you have entered an invalid access code for a specific number of times as you have programmed in Function Code 93 and the alarm mode will be activated and you will hear:

- **“One Long Beep”** every second for 30 seconds at the system’s speaker if Function Code 95 is set for mode “0” or
- The AeGIS will call to premise or remote location if Function Code 95 is set for mode “1”, and you will hear:
 - **“One Ring”** at a premise phone for 30 seconds if you do not answer the phone. If you answer the phone you will hear **“Nothing”** on the handset.
 - **“Standard Telephone Ring”** for 30 seconds if you do not answer the phone. If you answer the phone you will hear **“One Short Beep”** for 30 seconds.

6.6 How to Enable and Disable Call Forwarding.

The AeGIS 4000 has **Non-indexed** and **Indexed** call forwarding. The Non-indexed is stored on location 70 and Indexed is stored on 71,72, 73, 74 and 75. Enabling call forwarding can be done **locally** (via the system’s keypad) or **remotely** (from premise or remote location via a touch tone phone). The Non-indexed call forwarding is automatically enabled if the number is programmed on location 70 (see Chapter 3, 4 and 5).

6.6.1 Enable Indexed Call Forwarding via System’s Keypad (Local)

Step 1 Press 0 and * simultaneously then release them.

Step 2 Press the associated **key** on the table below then press #. You will hear **“Three Short Beeps”**. If the phone number does not exist on the Index Number you will hear **“One Long Beep”**.

Function (Index Number)	Key
Enable call forwarding index number 71	71
Enable call forwarding index number 72	72
Enable call forwarding index number 73	73
Enable call forwarding index number 74	74
Enable call forwarding index number 75	75

Step 3 Wait for about 15 seconds before trying to call from the system.

6.6.2 Enable Indexed Call Forwarding from Premise Phone

Step 1 Pick up your handset and wait for a dial tone.

Step 2 Press # # and you will hear **“One Short Beep”**.

Step 3 Press the associated **key** on the table below. You will hear **“Three Short Beeps”** and you are disconnected. If the phone number does not exist on the Index Number, you will hear **“One Long Beep”**.

Function (Index Number)	Key
Enable call forwarding index number 71	71
Enable call forwarding index number 72	72
Enable call forwarding index number 73	73
Enable call forwarding index number 74	74
Enable call forwarding index number 75	75

6.6.3 Enable Indexed Call Forwarding from Remote Location

- Step 1** Pick up your handset and wait for a dial tone.
- Step 2** Dial the AeGIS phone number and you will hear **“One Short Beep”** if the gate is locked or **“Two Short Beeps”** if the gate is unlocked.
- Step 3** Press # then the 4-digit master code, you will hear **“One Short Beep”**.
- Step 4** Press the associated key on the table below, you will hear **“Three Short Beeps”** and you are disconnected. If the phone number does not exist on the Index Number, you will hear **“One Long Beep”**.

Function (Index Number)	Key
Enable call forwarding index number 71	1
Enable call forwarding index number 72	2
Enable call forwarding index number 73	3
Enable call forwarding index number 74	4
Enable call forwarding index number 75	5

6.7 How to Activate Automatic Call Forwarding

There are three different function codes (87, 88, and 89) need to be configured. You can configure them local or remote, see chapter 3, 4 and 5. Function Code 87 (Enable or Disable Automatic Call Forwarding) is enabled by default. Function Code 88 (Select Automatic Call Forwarding Index Number) is selected to Index 71 automatically if a phone number is programmed on Index 71. Function Code 89 (Set Automatic Call Forwarding Time) must be set shorter than the Talk Time (Function Code 91), otherwise the Automatic Call Forwarding will not work.

6.8 How to Unlock Cycle, Unlock Hold and Lock

You can perform all of the operations via the system's keypad (local) or remote (from premise or remote location).

6.8.1 Via the System's Keypad

- Step 1** Press 0 and # simultaneously then release. If you are in the programming mode, proceed to step 2.
- Step 2** Enter the 4-digit Master Code (factory default is 0000) and you will hear **“One Short Beep”**. If you entered an invalid master code you will hear **“One Long Beep”**, repeat step 1. Should your master code become lost or forgotten see section 3.3 Reset Master Code.
- Step 3** Enter 90 then #, you will hear **“One Short Beep”**.
- Step 4** Press 1 (to unlock hold) then press #, you will hear **“Two Long Beeps”** then **“One Short Beep”**. If you hear **“One Short Beep”**, means the door is unlocked or Press 0 (to lock) then press #, you will hear **“One Long Beep”** then **“One Short Beep”**.

NOTE: Unlock Cycle cannot be done locally via the system's keypad

- Step 5** Enter another Function Code to program another parameter otherwise press * to exit and you will hear **“Three Short Beeps”**.

6.8.2 From Premise Location

- Step 1** Pick up your handset and wait for a dial tone.
- Step 2** Press # # and you will hear **“One Short Beep”**.
- Step 3** Press 9 to Unlock Cycle, you will hear **“Two Short Beeps”** or Press 8 to Unlock Hold, you will hear **“Two Short Beeps”**. If door or gate is unlocked, you will hear **“No Beep”** or Press 0 to lock door or gate, you will hear **“One Short Beep”**. Then you are disconnected.

6.8.3 From Remote Location

- Step 1** Pick up your handset and wait for a dial tone and dial the system phone number. You will be connected to the system after a certain number of rings preprogrammed on Function Code 96 and you will hear **“One Short Beep”** if the gate is locked or **“Two Short Beeps”** if the gate is unlocked.
- Step 2** Press # then 4-digit Master Code and you will hear **“One Short Beep”** if the master code is accepted or the call will be disconnected if the master code is invalid.
- Step 3** Press 9 to Unlock Cycle, you will hear **“Two Short Beeps”** or Press 8 to Unlock Hold, you will hear **“Two Short Beeps”** or Press 0 to Lock. Then you are disconnected.

6.9 How to Hang-up AeGIS Calls from Premise or Remote Location

Hanging-up the AeGIS calls from a premise or remote location:

- Wait until the talk time expires or
- Hang-up the handset or
- Press * *

6.10 How to Call and Talk to the AeGIS from Premise or Remote Location

6.10.1 From Premise Location

- Step 1** Pick-up the handset.
- Step 2** Press # # and you will hear **“One Short Beep”**.
- Step 3** Press * and now you are ready to talk to the AeGIS system. You may press 9 to open door or gate.

6.10.2 From Remote Location

- Step 1** Pick-up the handset and wait for dial tone.
- Step 2** Dial the AeGIS phone number and you will hear **“One Short Beep”** if the gate is locked or **“Two Short Beeps”** if the gate is unlocked.
- Step 3** Press # then 4-digit master code and you will hear **“One Short Beep”** if your master code is accepted or you will hear **“One Long Beep”** if your master code is rejected and the system will disconnect.
- Step 4** Press *, you are ready to talk to the AeGIS system. You may press “9” to open door or gate.

6.11 How to use Alarm Notification

An alarm notification will occur if someone has been using incorrect access codes in order to gain access and the number of account has been exceeded the lockout-count limit. The system will provide an alarm notification local at the AeGIS system or remote (calling into a premise or remote location phone). Refer to section 3.23 Function Code 95.

Mode 0: the AeGIS 4000 will beep every second for 30 seconds and the system cannot be used for 60 seconds.

Mode 1: the AeGIS 4000 will call to a premise or remote location. If it calls to:

- **A premise:** distinctive ringing will be heard for 30 seconds if the call is not answered. If the call is answered, a connection will be established with the AeGIS system, you may talk to the visitor and press “9” to open door or gate.

- **A remote:** regular ring will be heard for 30 seconds if the call is not answered. If the call is answered, you will hear **beep ... beep ...** for 60 seconds. You may press “9” to open door or gate or press any other key to hang-up the call.

6.12 How to use an Auxiliary Input Pin (AUI)

The AUI can be set into three different modes and “**Two Short Beeps**” will be heard if the AUI input is activated.

- **Mode 0** is disabled.
- **Mode 1** is to unlock door or gate if AUI pin is shorted to ground (GND). Door or gate will remain unlock according to door open interval programmed on function code 92. You may connect a Postal Lock or a momentary switch to the AUI input.
- **Mode 2** is to unlock hold door or gate. You may connect a timer to the AUI input to unlock and lock door or gate according to the timer setting.

6.13 How to use Do not Disturb

The “Do not Disturb” feature is used to block any visitor call. The AeGIS system will not allow a visitor to press # to call out. Any other operation will still work. Refer to function code 97 to enable Do not Disturb mode.

6.14 How to Use Speed Dialing

You may use a **speed dialing** for frequently used function codes such as Unlock Door Cycle, Unlock Door Hold and Lock Door, etc. You must put PAUSE between the key presses.

Chapter 7. Trouble Shooting Guides

SOLUTIONS and SUGESTIONS	
AUDIO PROBLEMS	
No tone when keys are pressed.	<ul style="list-style-type: none"> ▪ No tone when the key is pressed unless if you are in programming mode. ▪ Check the speaker and microphone connection on terminal marked speaker and microphone (see fig.21.). The snap on clip connector on the speaker and microphone connector must be facing inside the board. ▪ Check the red and orange wires; make sure they are soldered into the speaker. ▪ Turn the system OFF and disconnect the speaker connector from the board. Set your meter to Ohm and use 50 Ohm scale or higher. Put the two probes into the speaker (+) and (-) (polarity not important) and the meter should read about 24 Ohms. ▪ Call Technical Support for help.
Visitor can't hear the tenant voice from the system but tenant can hear visitor.	<ul style="list-style-type: none"> ▪ Check the speaker and microphone connection on terminal marked speaker and microphone (see fig.21.). The snap on clip connector on the speaker and microphone connector must be facing inside the board. ▪ Check the red and orange wires; make sure they are soldered into the speaker. ▪ Turn the system OFF and disconnect the speaker connector from the board. Set your meter to Ohm and use 50 Ohm scale or higher. Put the two probes into the speaker (+) and (-) (polarity not important) and the meter should read about 24 Ohms. ▪ Call Technical Support for help.
Tenant can't hear the visitor voice but visitor can hear the tenant voice.	<ul style="list-style-type: none"> ▪ Check the speaker and microphone connection on terminal marked speaker and microphone (see fig.21.). The snap on clip connector on the speaker and microphone connector must be facing inside the board. ▪ Check the brown and black wires; make sure they are soldered into the microphone. ▪ Call Technical Support for help.
COMMUNICATION PROBLEMS	
Can't call to the premise location.	<ul style="list-style-type: none"> ▪ Check the power (12.8 VAC under load). ▪ Disable the call-forwarding mode. ▪ Erase the system to factory default. ▪ Check the system wiring connections.
Can't call to the remote location.	<ul style="list-style-type: none"> ▪ Check the power (12.8 VAC under load). ▪ Enable the call-forwarding mode. ▪ Check the call forwarding phone number programmed. ▪ Check the call forwarding phone number programmed. ▪ Make sure the phone line is not used. ▪ Erase the system to factory default. ▪ Check the system wiring connections.

	<ul style="list-style-type: none"> ▪ Check the phone line with a telephone test set.
Radio station problem.	<ul style="list-style-type: none"> ▪ Disconnect the phone line from the AeGIS system and connect a telephone test set the phone line and try to place a call. ▪ Check the grounding on the AeGIS system and telephone line. The Aegis's cabinet must be grounded to an earth ground. The telephone line shield must be grounded at the telephone terminal block, not on the AeGIS cabinet. ▪ Shielded wires must be used as part of the installation requirements. ▪ Disconnect the ground wire (marked GND on the board at 5 pins terminal) from the board. ▪ Install a Modular RFI Filter.
Static problem.	<ul style="list-style-type: none"> ▪ Disconnect the phone line from the AeGIS system and connect a telephone test set the phone line and try to place a call. ▪ Check the grounding on the AeGIS system and telephone line. The Aegis's cabinet must be grounded to an earth ground. The telephone line shield must be grounded at the telephone terminal block, not on the AeGIS cabinet. ▪ Shielded wires must be used as part of the installation requirements. ▪ Disconnect the ground wire (marked GND on the board at 5 pins terminal) from the board.
Sound keeps breaking out.	<ul style="list-style-type: none"> ▪ Check for echo in the building. ▪ If the AeGIS is installed in a noisy environment, you may experience with this problem. ▪ Visitor and tenant can't talk simultaneously. ▪ Try to speak a little further from the system.
GATE PROBLEMS	
Number 9 does not open the door or gate.	<ul style="list-style-type: none"> ▪ Make sure there is power on the door or gate strike. ▪ Check for loose connection on the door or gate strike wires on COM and NO (if you use "Normally Open") or COM and NC (if you use "Normally Close"). ▪ Short the two wires on COM and NO, the door or gate should open or remove the wire on COM door or gate should open. If door or gate does not open, you may have a problem with door or gate strike. ▪ Test the relay and follow the steps below: <ol style="list-style-type: none"> 1. Set your multi-meter to Ohm (touch the two probes, the meter will read about 0 (zero value). 2. Connect the probes to COM and NO (if "Normally Open" strike is used, the meter will read as an open circuit) or COM and NC (if "Normally Close" strike is used your meter will read about 0 value). 3. Press * and a valid 4-digit access code <ul style="list-style-type: none"> ▪ Your meter should 0 (zero value) if COM and NO contacts are used; otherwise the system's relay is bad. ▪ Your meter should read as an

	open-circuit if COM and NC contacts are used, otherwise the system's relay is bad.
Number 9 does not open the door or gate but the 4-digit access code opens the door or gate.	<ul style="list-style-type: none"> ▪ Touch-tone phone must be used. ▪ The premise phone provides DTMF tone when number 9 key is pressed.
KEYPAD PROBLEMS	
Can't logon to programming mode.	<ul style="list-style-type: none"> ▪ The red dots along the ribbon cable must be facing toward the blue terminal connectors. ▪ Turn the power OFF and disconnect the keypad's ribbon cable from the board and reconnect it then turn the power ON.

The technical support team at Pach and Company are highly trained and committed to providing you with the best in support and repair services. Our Services are available between **7:30 AM – 4:30 PM Pacific Standard Time.**

Toll free (888) 678-7224.

Chapter 8 Parameters Worksheet

You must keep accurate system's parameters and database records at all time for future reference.

System's Parameter Worksheet

Parameter	Function Code	Default Setting	Change to
Master Code	00	0000	
Talk Time	91	060 Seconds	
Door Open Interval	92	12 Seconds	
Lock-Out Count	93	3 Tries	
System Answer Mode	96	Disable (default 0)	
AUI MODE	94	Mode 0 (disable)	
Alarm Mode	95	Mode 0 (local beep)	

Personal Access Codes

Index Number	4-Digit CCESS CODE	Index Number	4-Digit Access Code
01		26	
02		27	
03		28	
04		29	
05		30	
06		31	
07		32	
08		33	
09		34	
10		35	
11		36	
12		37	
13		38	
14		39	
15		40	
16		41	
17		42	
18		43	
19		44	
20		45	
21		46	
22		47	
23		48	
24		49	
25		50	

Call Forwarding Phone Numbers

Non-Index	Phone number
70	
Index	Phone number
71	
72	
73	
74	
75	