



SENSORS & SWITCHES

425 Series Narrow Style Door Activator Button Switches



#425B-BLK
(Blue Powder Coat Face Plate, Black Button Switch)

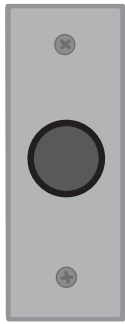

#425SS-BLK
(Stainless Steel Face Plate, Black Button Switch)



#425B-RED
(Blue Powder Coat Face Plate, Red Button Switch)



#425SS-RED
(Stainless Steel Face Plate, Red Button Switch)



1½" Self-Sticking Mylar Face Plate Label
(Blue Background/White Legend)



Product Name

425 Series Narrow Style Door Activator Button Switches

Manufacturer

MS Sedco
8701 Castle Park Drive
Indianapolis, IN 46256
Phone: (800) 842-2545
(317) 842-2545
Fax: (800) 849-3387
(317) 849-3387

Email: custsvc@mssedco.com
www.mssedco.com

Product Description

BASIC USE

The 425 Series narrow style switches are designed to provide reliable, unobtrusive activation of any automatic door.

The 425 Series features 1 11/16" x 4 1/2" face plates in either stainless steel or blue powder coated aluminum. They include self-sticking mylar labels for customizing the face plate.

Mount the 425 Series directly onto the jamb of an automatic door (fits a 1 3/4" frame) or in MS Sedco's optional surface mount box.

Each unit is quality built utilizing heavy gauge metals, aircraft quality rivets and screws, durable finishes and the most reliable microswitch in the industry.

Technical Data

- 1 11/16" x 4 1/2" Face Plates in Stainless Steel or Blue Powder Coated Aluminum
- 1" Diameter Button Switch

(Black or Red)

- UL Listed Micro Switch, SPDT, Mom., 15 Amp @ 125V AC
- Fits 1 3/4" Frame or MS Sedco #1106 Surface Mounting Box
- Includes Self-Sticking Mylar Face Plate Labels

DIMENSIONS

See Reverse

APPLICABLE STANDARDS

American National Standards Institute (ANSI) - Building Hardware Manufacturers Association (BHMA) - ANSI/BHMA A156.19.

APPROVALS

UL (Micro Switch)

Installation

The 425 Series Narrow Style Button Switch is easy to install.

Using the mounting template provided, make cutout in the door frame. Connect the necessary signal wires to the appropriate switch contacts (COM and N.O. are standard). Secure the switch assembly to the door frame and attach the face plate. Apply desired face plate label.

Availability & Cost

AVAILABILITY

Available internationally from manufacturer's authorized distributors; contact MS Sedco for the location of nearest distributor.

425 Series Narrow Style Door Activator Button Switches

SENSORS & SWITCHES

COST

Cost information on MS Sedco products is available from the manufacturer's authorized distributors.

Warranty

MS Sedco, Inc. guarantees this product to be free from manufacturing defects for one year from date of installation. Unless MS Sedco is notified of the date of installation, the warranty will be in effect for one year from the date of shipment from our factory. If, during the first year, this product fails to operate and has not been tampered with or abused, the unit can be returned prepaid to the factory and be repaired free of charge. After one year, the unit will be repaired for a nominal service charge. **Limited warranty is in lieu of all other warranties, expressed or implied, including any implied warrantability of merchantability. No representative or person is authorized to assume for MS Sedco any other liability in connection with the sale of our products. All warranties are limited to the duration of this written limited warranty. In no event shall MS Sedco be liable for any special, incidental, consequential or other damage arising from any unclaimed breach of warranty as to its products or services.**

Maintenance

MS Sedco recommends that all maintenance and adjustments be performed by an AAADM Certified Technician.

Technical Services

MS Sedco's staff of factory trained sales and service personnel offer design assistance and technical support. Local distributors are also available to assist in selecting appropriate devices for specific uses and to provide onsite installation.

Filing Systems

- Sweet's
- Additional product information is available from the manufacturer upon request.

DIMENSIONS

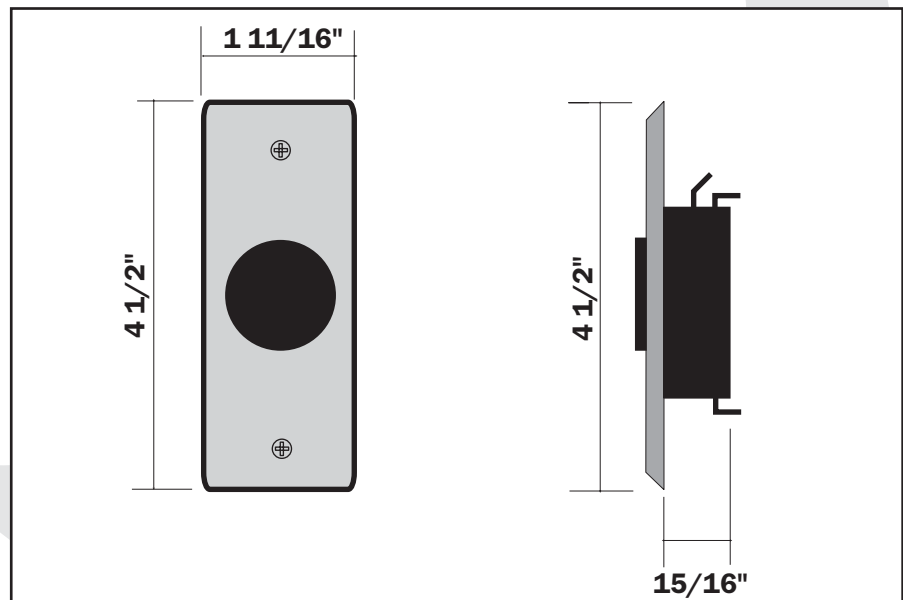

52003