

STORAGE



Storage Boxes

- Secure storage for job site tools
- Heavy duty hinges for durability
- Side handles for easy lifting
- Oven-cured paint
- Heavy duty - 16 gauge construction
- Models 101, 102, and 103 have pre-drilled holes for caster mounting
- Large bottom runners for easy lifting



Model 103



Model 104



Model 101

Catalog Number	Description	L	H	D	Weight
101	Storage Box —	48" length	30" height	30" depth	177 lbs.
102	Storage Box —	60" length	24" height	24" depth	170 lbs.
103	Storage Box —	60" length	48" height	30" depth	315 lbs.
104	Storage Box —	31" length	15" height	18" depth	51 lbs.
8-0501	Storage Box —	23" length	17" height	20" depth	36 lbs.

www.currenttools.com

P.O. Box 17026 • Greenville, SC 29606 • 864.244.1201 • fax 864.244.5860 • 800.230.5421

Current Tools 
FOR THE PROFESSIONAL ELECTRICIAN



STORAGE

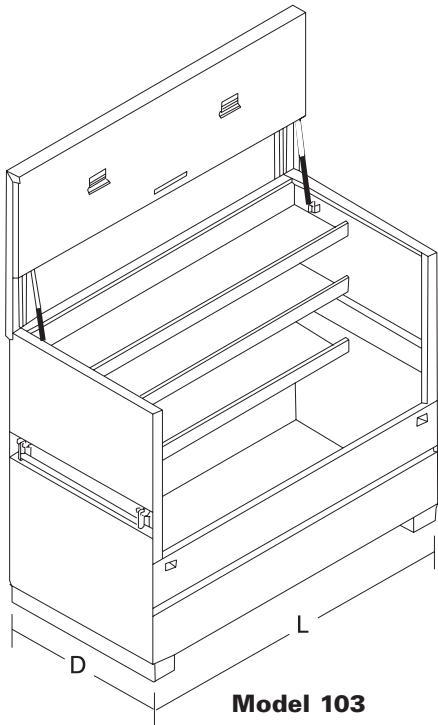

Model 103

Model 101 and Model 102

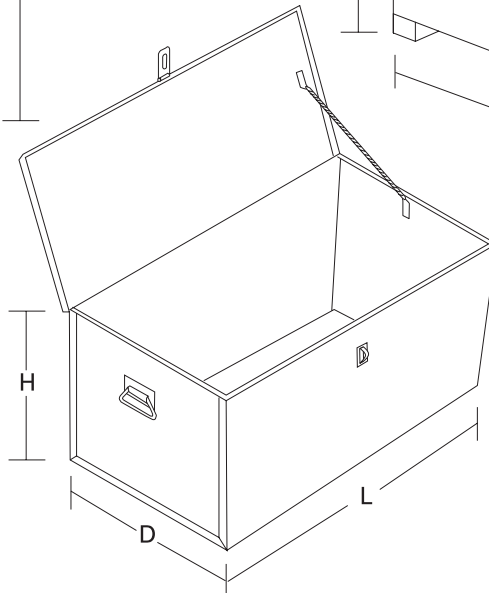
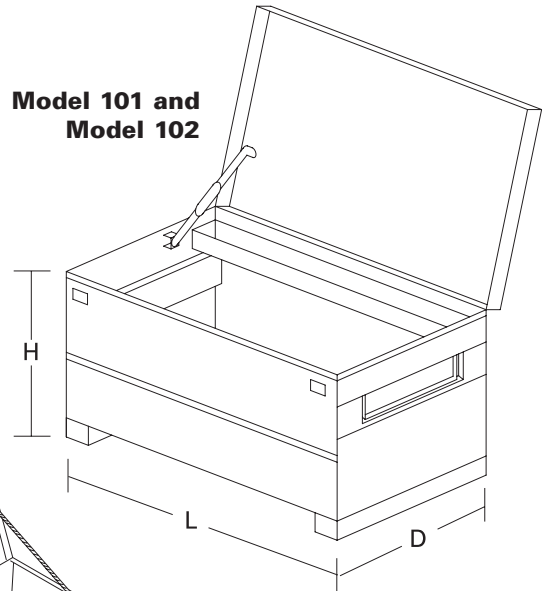

Model 104 and Model 8-0501

Caster Set

- Heavy duty design to move storage boxes around the job site
- Each set has 2 swivel and 2 fixed casters
- Mounting bolts are provided with each caster set



Catalog Number	Description	Weight
506	6" wheel set; 2 swivel and 2 fixed	20 lbs.



Current Tools
FOR THE PROFESSIONAL ELECTRICIAN

www.currenttools.com

P.O. Box 17026 • Greenville, SC 29606 • 864.244.1201 • fax 864.244.5860 • 800.230.5421